

---

REPAIR MANUAL  
&  
PARTS LIST

---

FOR

**FUJICA ST-705**

---



**FUJI PHOTO FILM CO., LTD.**

26-30, Nishiazabu 2-Chome, Minato-ku, Tokyo 106, Japan

# CONTENTS

Please Note: Pages 6, 28, 96 & 102 are blank and have been omitted.

	Page
I. TROUBLESHOOTING .....	1
1. METER NEEDLE DOES NOT DEFLECT .....	2
2. METER NEEDLE DEFLECTS CONTINUOUSLY TO THE MAXIMUM .....	2
3. METER DOES NOT OPERATE ACCORDINGLY WITH SELECTED APERTURE OR SHUTTER SPEED OR CHANGED BRIGHTNESS OF OBJECT .....	2
4. OVER OR UNDER EXPOSURE .....	3
5. DUPLICATE EXPOSURE .....	3
6. FILM IS SCARRED OR SCRATCHED .....	4
7. LIGHT LEAKING .....	4
8. FILM ADVANCE LEVER DOES NOT MOVE .....	4
9. MIRROR DOES NOT COME DOWN .....	5
10. INCORRECT SHUTTER SPEED .....	5
11. FLASH DOES NOT SYNCHRONIZE .....	5
II. DISASSEMBLY .....	7
1. TOP COVER ASSEMBLY (1-1) .....	8
2. AMPLIFIER ASSEMBLY (2-34) .....	10
3. SHUTTER RESISTOR ASSEMBLY (2-1) .....	10
4. COUNTER ASSEMBLY (2-48) .....	12
5. PENTA PRISM ASSEMBLY (3-1) AND PHOTOCCELL ASSEMBLY (2-43) ....	14
6. PRISM (3-6) .....	14
7. FOCUSING SCREEN ASSEMBLY (3-12) .....	14
8. BOTTOM COVER (1-70) .....	16
9. LENS MOUNT ASSEMBLY (1-46) .....	16
10. BACK COVER ASSEMBLY (1-76) .....	16
11. SELF-TIMER ASSEMBLY (3-101) .....	18
12. SYNCHRO-CONTACT ASSEMBLY (3-21) AND BRAKE ASSEMBLY (3-35) .....	18
13. REMOVING FOCAL PLANE SHUTTER ASSEMBLY .....	20
14. DISASSEMBLING FOCAL PLANE SHUTTER ASSEMBLY .....	22
15. MAIN BODY ASSEMBLY .....	26

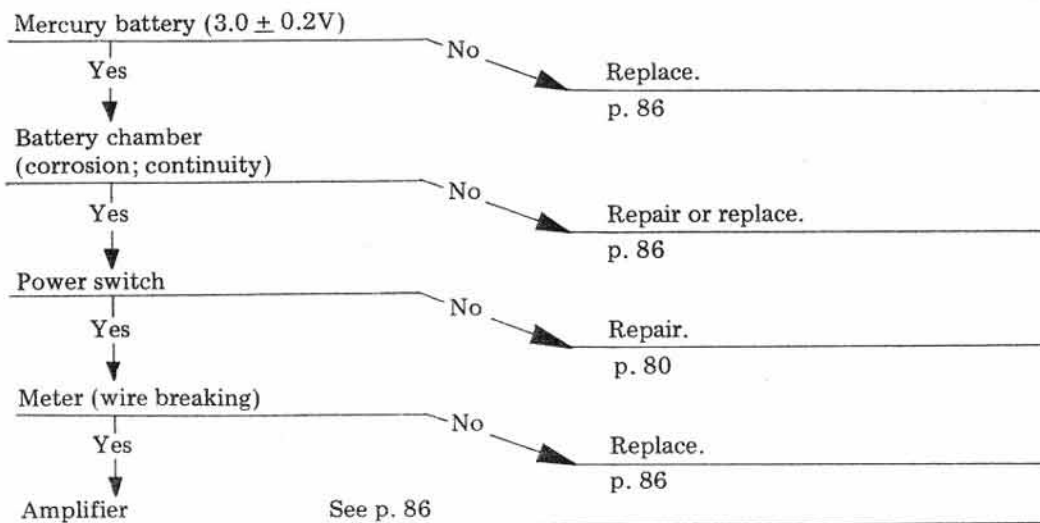
	Page
<b>III. REPAIR &amp; ADJUSTMENT</b> .....	29
1. MAIN BODY ASSEMBLY .....	30
2. FOCAL PLANE SHUTTER ASSEMBLY .....	36
3. ADJUSTMENT OF 45° ALIGNMENT OF THE MIRROR .....	62
4. STOPPED-DOWN/FULL-APERTURE LIGHT CHANGEOVER SWITCH ASSEMBLY .....	64
5. ADJUSTMENT OF CONTACT POSITION FOR F-VALUE APERTURE RESISTOR ASSEMBLY (4-215) .....	66
6. INSTALLATION OF LENS MOUNT ASSEMBLY (1-46) AND ADJUSTMENT OF FLANGEBACK .....	68
7. LENS MOUNT ASSEMBLY (1-46) .....	70
8. VIEWFINDER .....	74
9. INSTALLATION OF EXPOSURE COUNTER AND ADJUSTMENT OF ADVANCEMENT .....	78
10. INSTALLATION OF SHUTTER RESISTOR ASSEMBLY (2-1) .....	78
11. ADJUSTMENT OF MAIN SWITCH FOR EXPOSURE METER CIRCUIT .....	80
12. ADJUSTMENT OF FILM ADVANCEMENT LOCK AND LOCK RELEASE MECHANISM .....	80
13. INSTALLATION OF AMPLIFIER AND WIRING .....	82
14. ADJUSTMENT OF EXPOSURE METER .....	84
15. CHECKING EXPOSURE METER .....	86
16. INSTALLING TOP COVER ASSEMBLY (1-1) .....	90
17. INSTALLING FILM ADVANCE LEVER ASSEMBLY (1-98), FILM REWIND KNOB ASSEMBLY (1-33) AND REWIND BUTTON (1-71) .....	92
18. LIGHT SHIELDING PARTS .....	94
 <b>IV. INSPECTION</b> .....	 97
 <b>V. PARTS LIST</b> .....	 103

I.  
**TROUBLESHOOTING**



# I. TROUBLESHOOTING

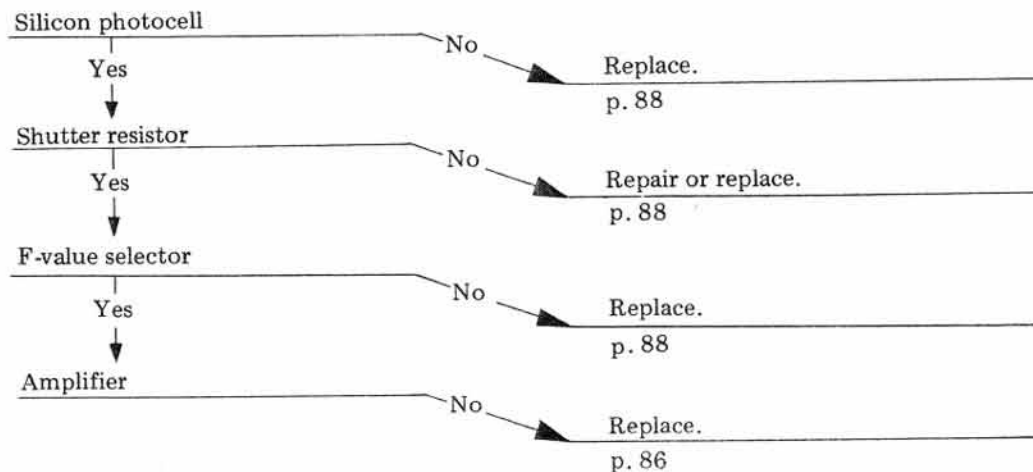
## 1. METER NEEDLE DOES NOT DEFLECT



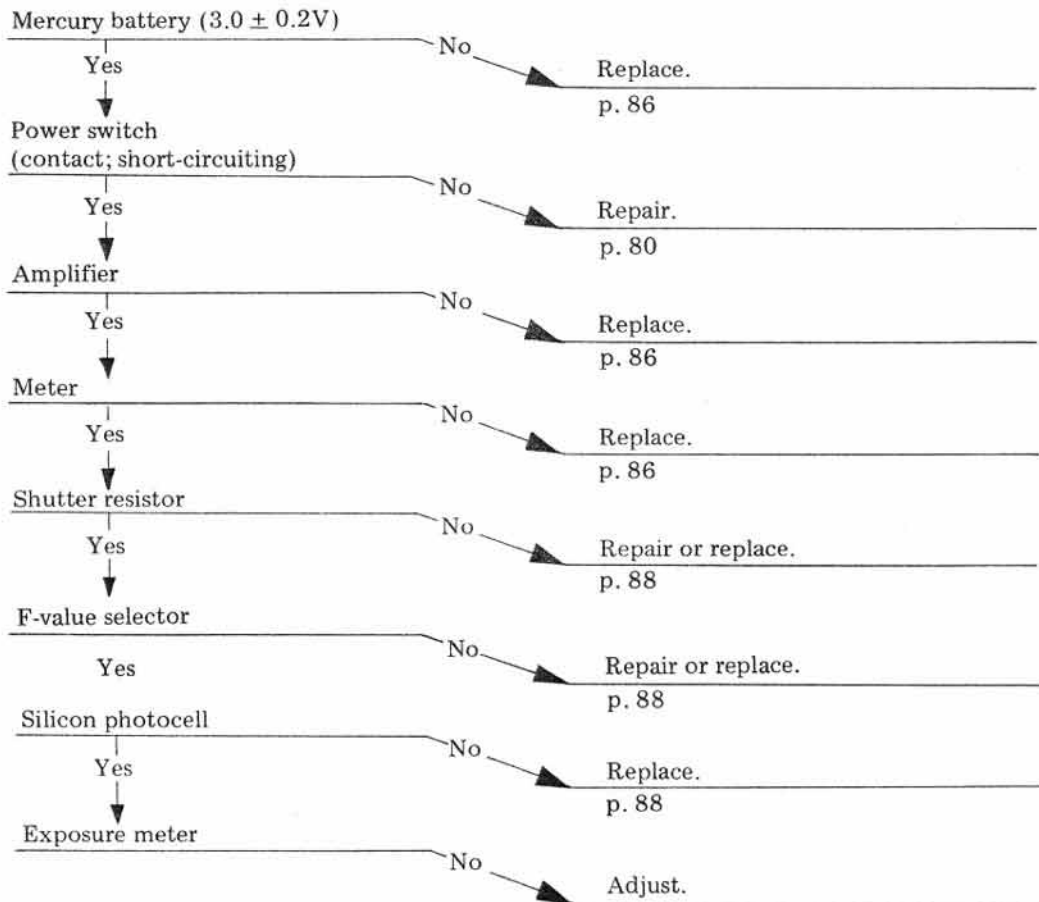
## 2. METER NEEDLE DEFLECTS CONTINUOUSLY TO THE MAXIMUM



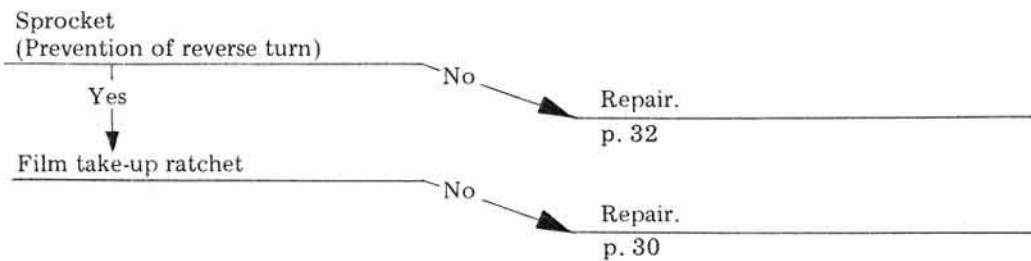
## 3. METER DOES NOT OPERATE ACCORDINGLY WITH SELECTED APERTURE OR SHUTTER SPEED OR CHANGED BRIGHTNESS OF OBJECT



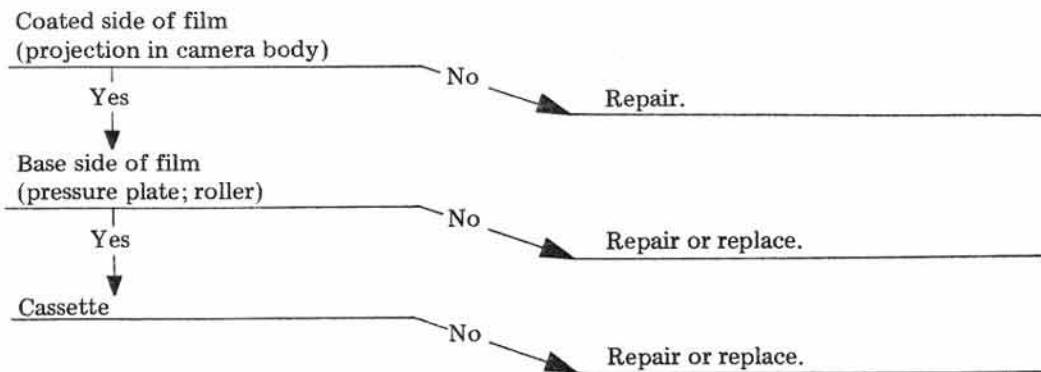
4. OVER OR UNDER EXPOSURE



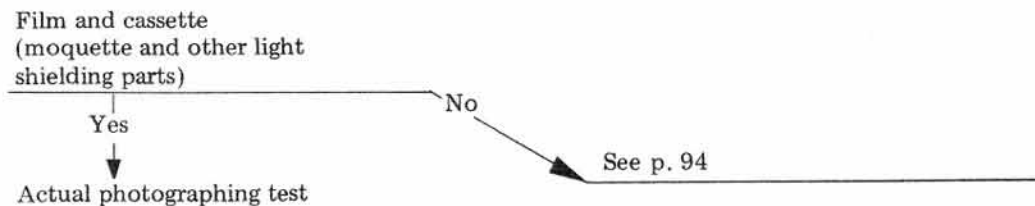
5. DUPLICATE EXPOSURE



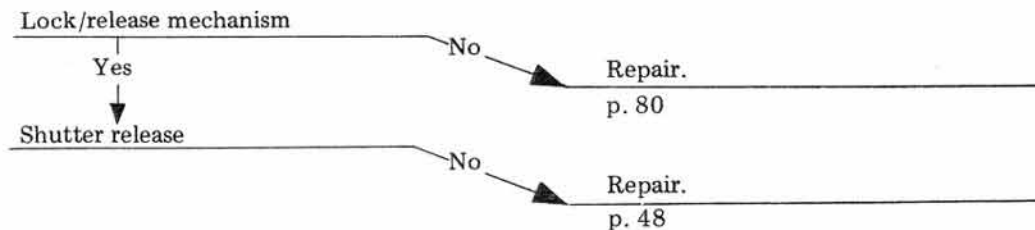
### 6. FILM IS SCARRED OR SCRATCHED



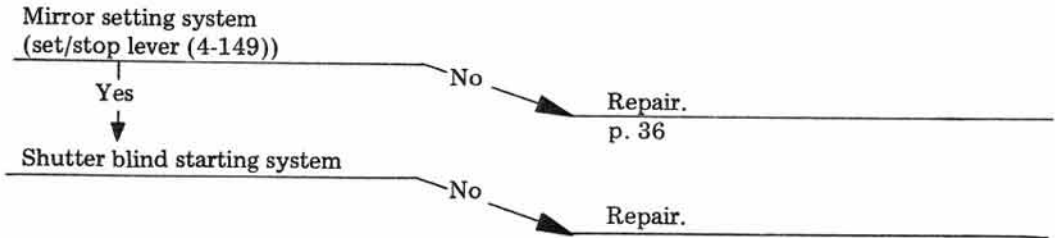
### 7. LIGHT LEAKING



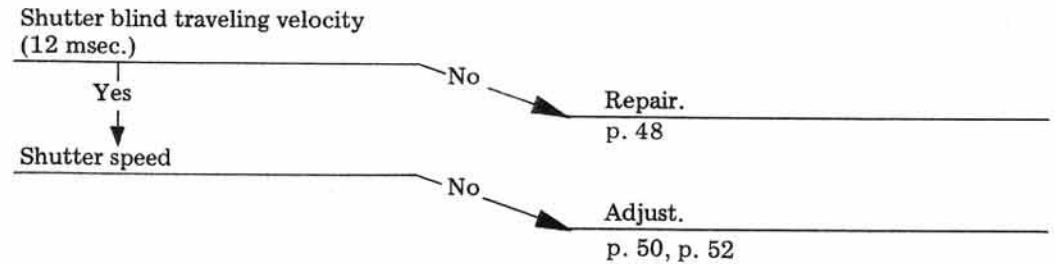
### 8. FILM ADVANCE LEVER DOES NOT MOVE



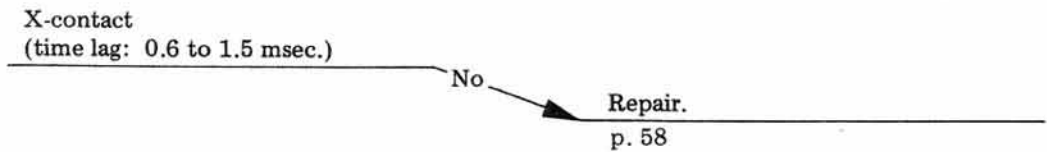
9. MIRROR DOES NOT COME DOWN



10. INCORRECT SHUTTER SPEED



11. FLASH DOES NOT SYNCHRONIZE



II.  
**DISASSEMBLY**

## II. DISASSEMBLY

### 1. TOP COVER ASSEMBLY (1-1)

a. Film rewind knob assembly (1-33)

Hold the rewind shaft (2-32), and turn the film rewind knob assembly (1-33) counterclockwise to remove it.

b. Film advance lever assembly (1-98)

Turn the screw (1-96) counterclockwise with a piece of rubber or other proper tool to remove it, and remove the film advance lever assembly (1-98).

c. Remove the cap (1-5).

d. Turn the ring (1-12) counterclockwise with a piece of rubber or other proper tool, and remove it. (Recommend repair tool (J306) be used.)

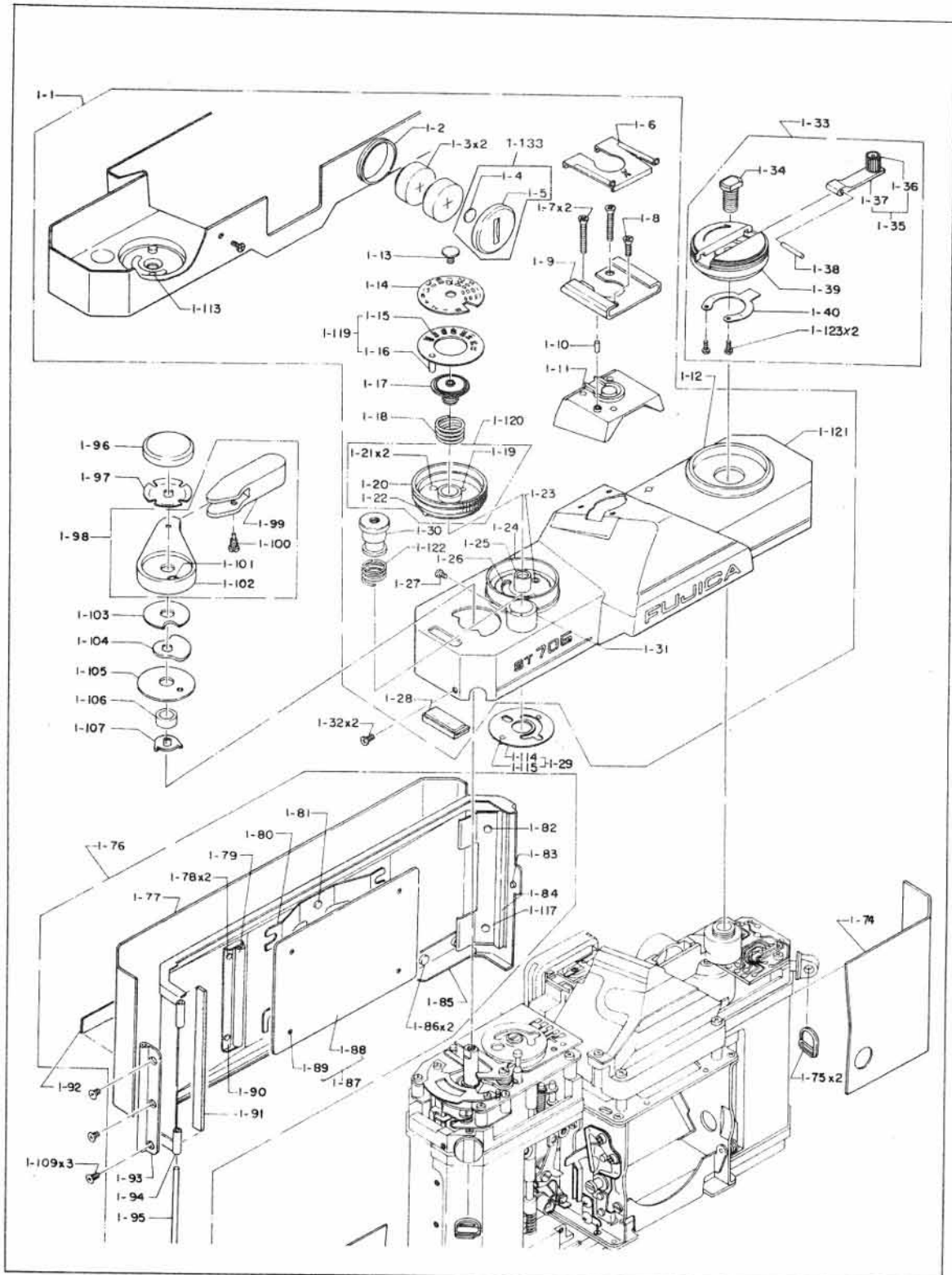
e. Remove two screws (1-32).

f. Pull up the top cover assembly (1-1) slowly and carefully.

NOTE: 1. Pay attention for the lead wire connected to the accessory shoe.

2. Be careful not to lose connector plate assembly (1-29).

Fig. 1



## 2. AMPLIFIER ASSEMBLY (2-34)

- a. Unsolder and disconnect six lead wires (6-1, 6-2, 6-3, 6-5, 6-8, 6-10, 6-23 and 6-24) from the printed circuit board of the amplifier assembly (2-34).
- b. Unsolder and disconnect the lead wire (6-9) from the contact spring (2-25).
- c. Unsolder and disconnect two lead wires (6-11 and 6-12) from the transit plate assembly (2-23).
- d. Remove the screw (2-33).
- e. With the lead wires connected to the transit plate assembly, remove the transit plate assembly (2-23).

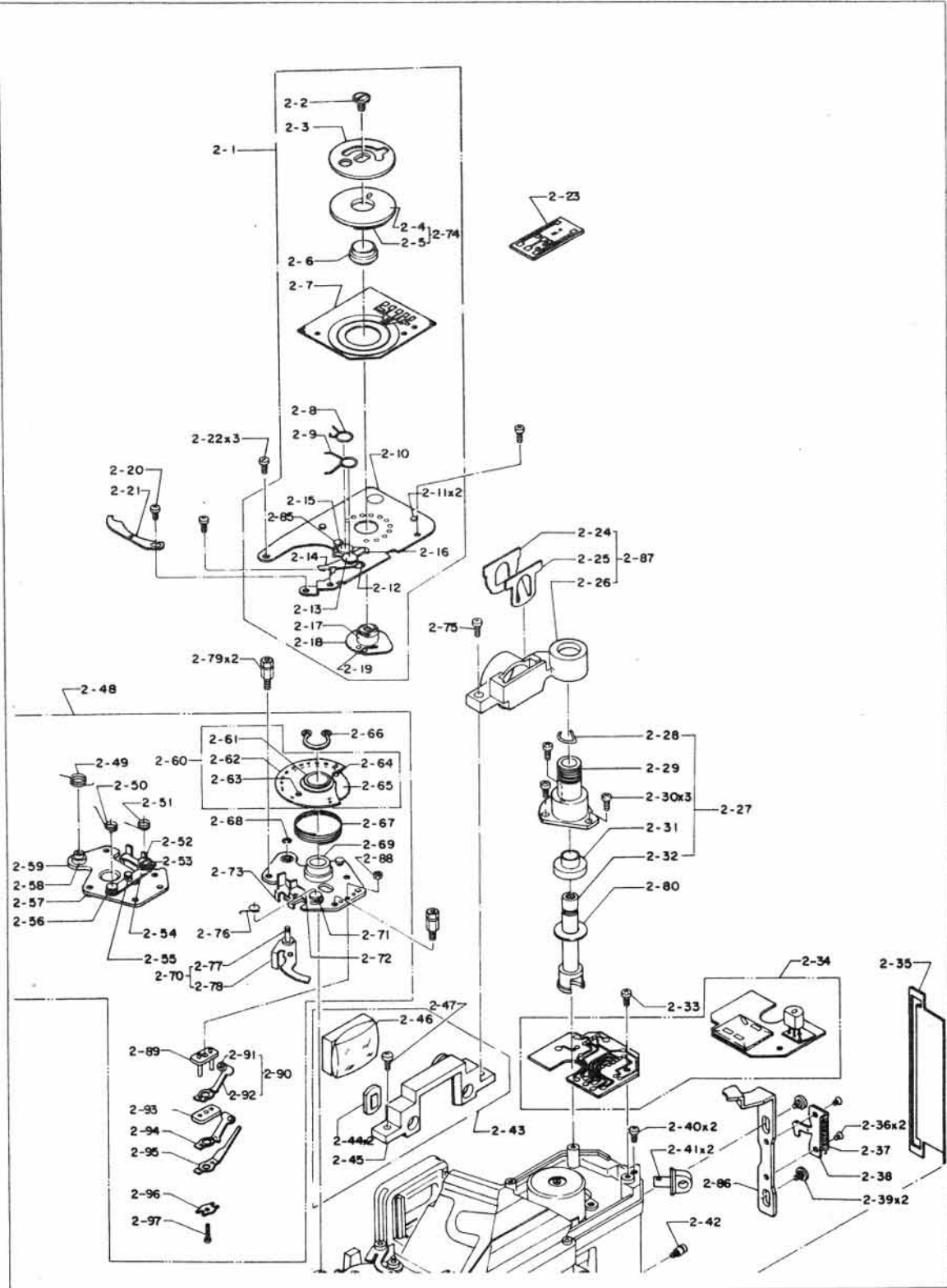
## 3. SHUTTER RESISTOR ASSEMBLY (2-1)

- a. Disconnect terminals of lead wires (6-5, 6-11, 6-12 and 6-23).
- b. Remove the screw (2-20), and remove the index plate (2-21).
- c. Remove three screws (2-22).
- d. Remove the shutter resistor assembly (2-1) upward.
- e. Be careful not to lose the coupling (3-40).

10



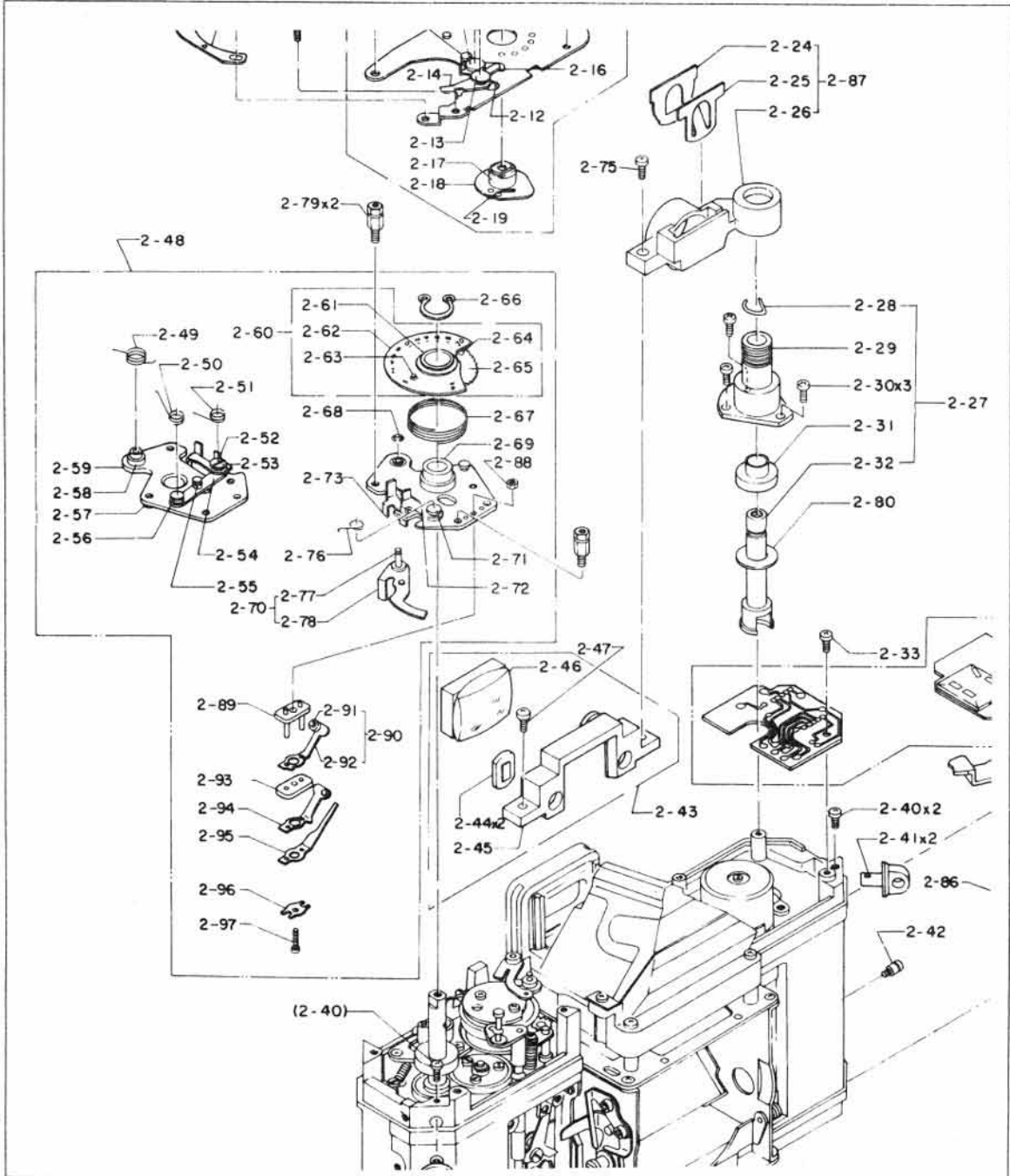
Fig. 2



4. COUNTER ASSEMBLY (2-48)

- a. Turn two columns (2-79) counterclockwise, and remove them.
- b. Remove the counter assembly (2-45) upward.

Fig. 3



5. PENTA PRISM ASSEMBLY (3-1) AND PHOTOCCELL ASSEMBLY (2-43)

- a. Remove screws (2-47 and 2-75), and remove the photocell assembly (2-43).
- b. Remove two screws (3-11).

6. PRISM (3-6)

When cleaning inside of the viewfinder, remove the prism (3-6) alone as described below.

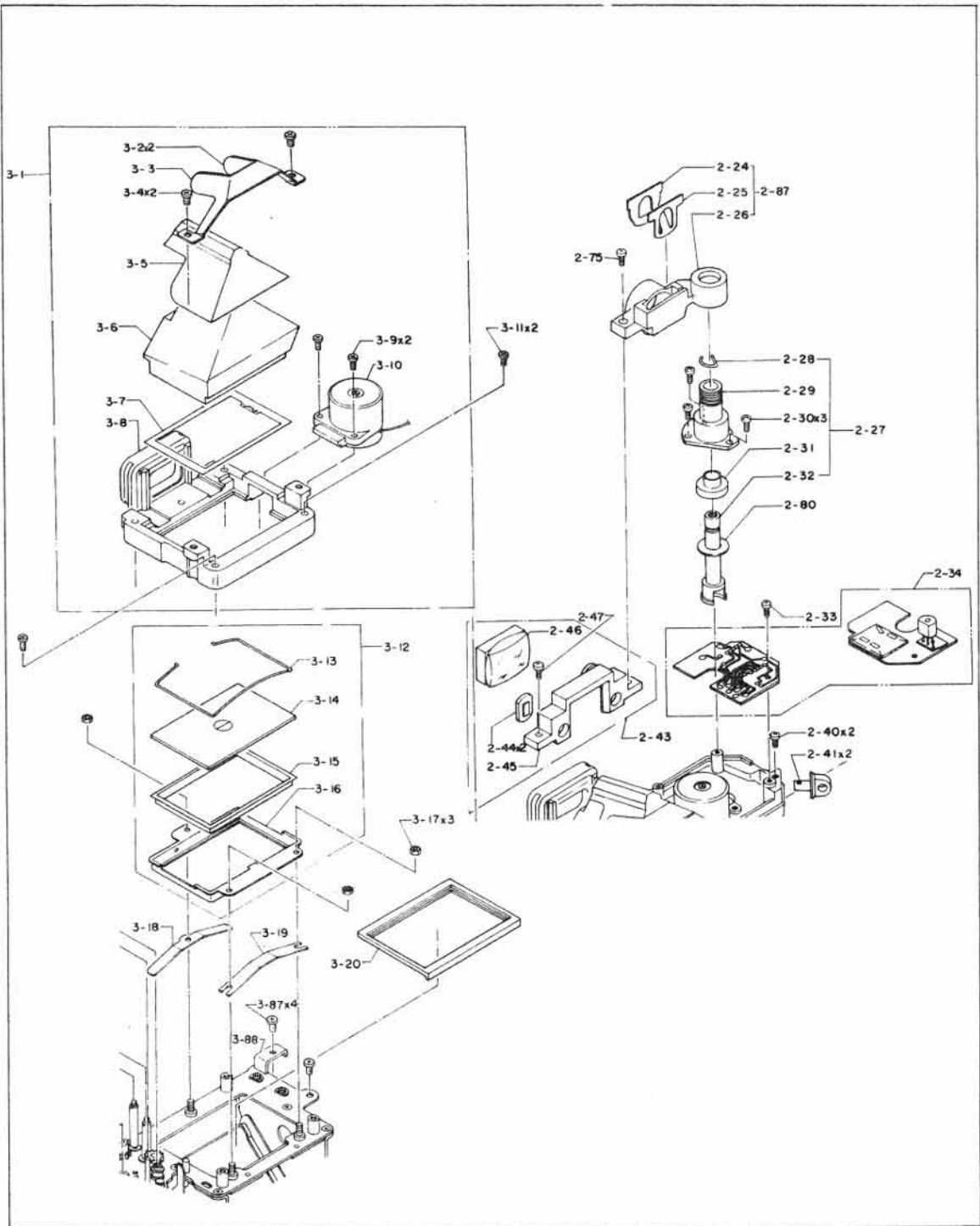
- a. Remove two screws (3-4).
- b. Hold the rough surface of the prism, and remove it.
- c. Carefully handle the frame (3-7). It is made of film.

7. FOCUSING SCREEN ASSEMBLY (3-12)

Remove three screws (3-17), and remove the focusing screen assembly (3-12).

NOTE: Be careful not to lose leaf springs (3-18 and 3-19).

Fig. 4



**8. BOTTOM COVER (1-70)**

Remove two screws (1-72), and remove the bottom cover (1-70).

NOTE: Be careful not lose the rewind button (1-71).

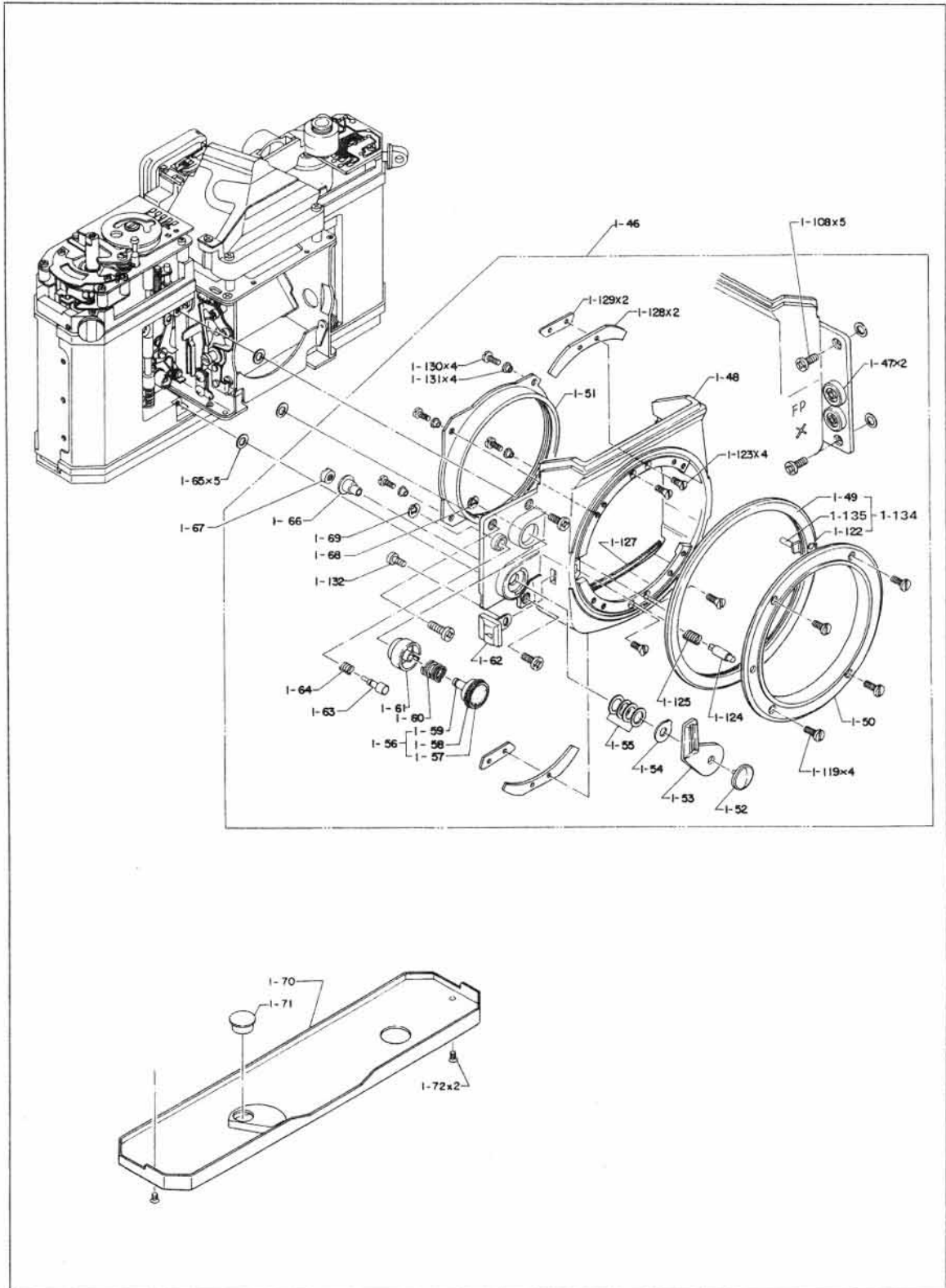
**9. LENS MOUNT ASSEMBLY (1-46)**

- a. Use solvent such as ketone to solve Pliobond, and peel off leathers (1-74 and 1-73).
- b. Set the self-timer in a half way.
- c. Remove four screws (1-108).
- d. Remove the lens mount assembly (1-46) forward and carefully so as not to lose the shaft (1-67).

**10. BACK COVER ASSEMBLY (1-76)**

Remove three screws (1-109), and remove the back cover assembly (1-76).

Fig. 5



**11. SELF-TIMER ASSEMBLY (3-101)**

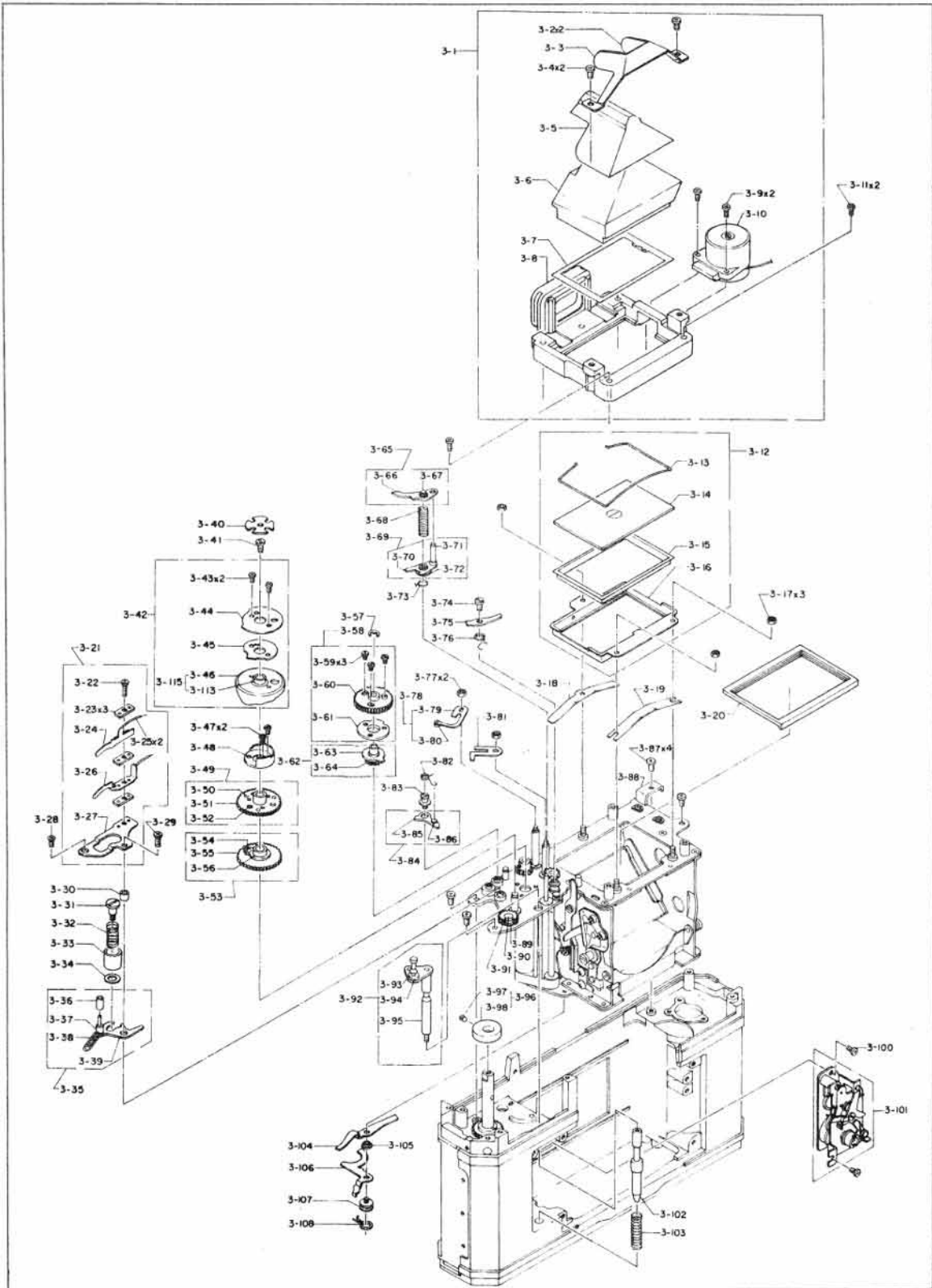
- a. Use solvent such as ketone to solve Pliobond used in the joint between shutter release shaft assembly (3-92) and release shaft (3-102), and separate them by turning the shutter release shaft assembly and release shaft counterclockwise.
- b. Remove two screws (3-100), and remove the self-timer assembly.

**12. SYNCHRO-CONTACT ASSEMBLY (3-21) AND BRAKE ASSEMBLY (3-35)**

- a. Disconnect two lead wires (3-25).
- b. Remove screws (3-28 and 3-29).
- c. Remove the synchro-contact assembly carefully so as not to lose the collar (3-30).
- d. Remove the screw (3-31).
- e. Remove the spring (3-38) carefully so that it is not deformed. Recommend the screw (5-18) to which the spring has been hooked be removed.
- f. Remove the brake assembly carefully. Helicolube/Molykote mixed grease has been applied.



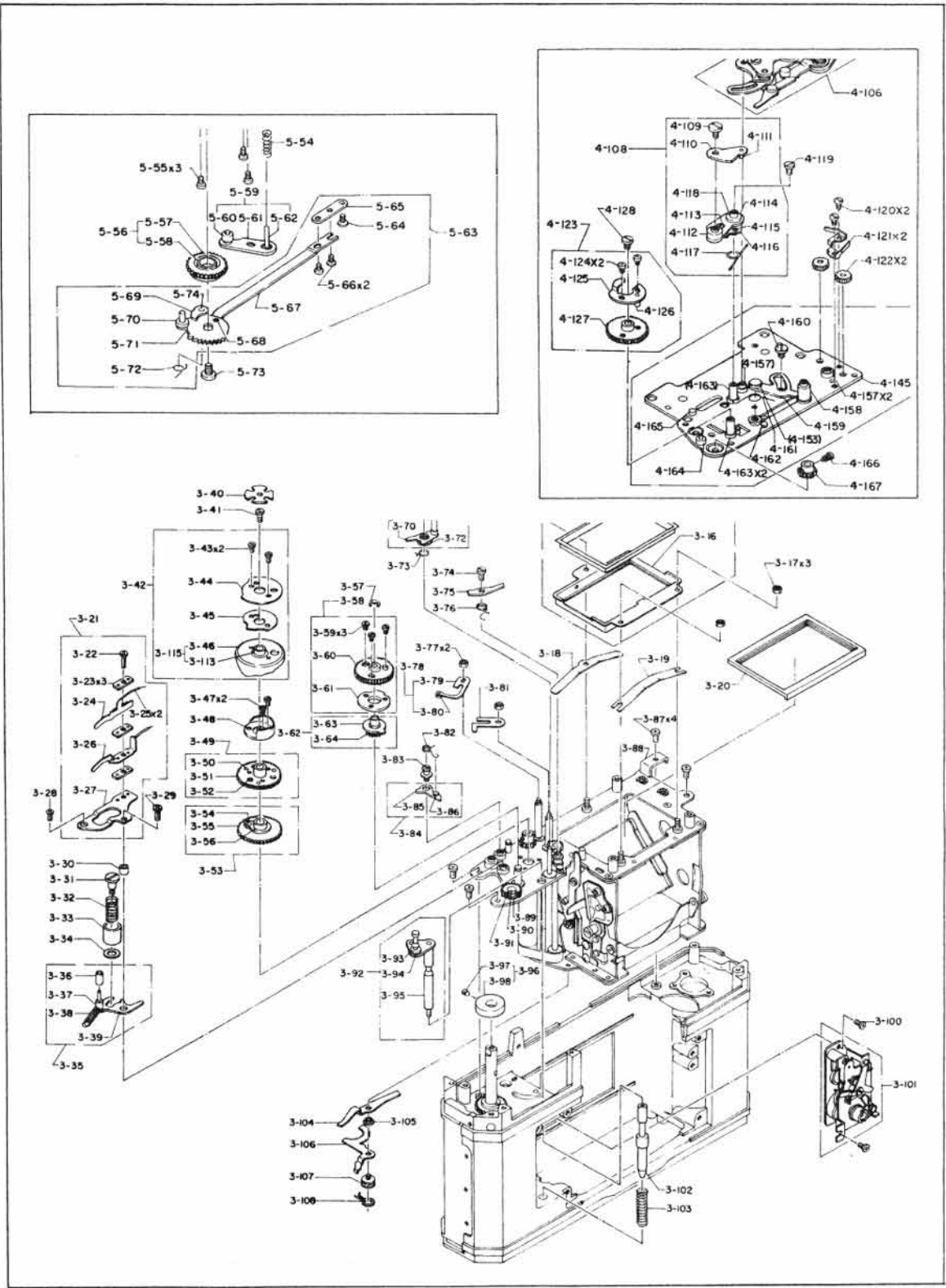
Fig. 6



### 13. REMOVING FOCAL PLANE SHUTTER ASSEMBLY

- a. Completely release the shutter.
- b. Remove the screw (5-64), and separate the connecting plate (5-65) from the connecting shaft (4-158).
- c. Remove the screw (4-128), and remove the gear assembly (4-123).
- d. Remove the screw (3-107), and remove the lever (3-104).
- e. Remove the E-clip (3-57), and remove the clutch plate assembly (3-58).
- f. Remove four screws (3-87).
- g. Remove the shutter assembly carefully toward the top.

Fig. 7

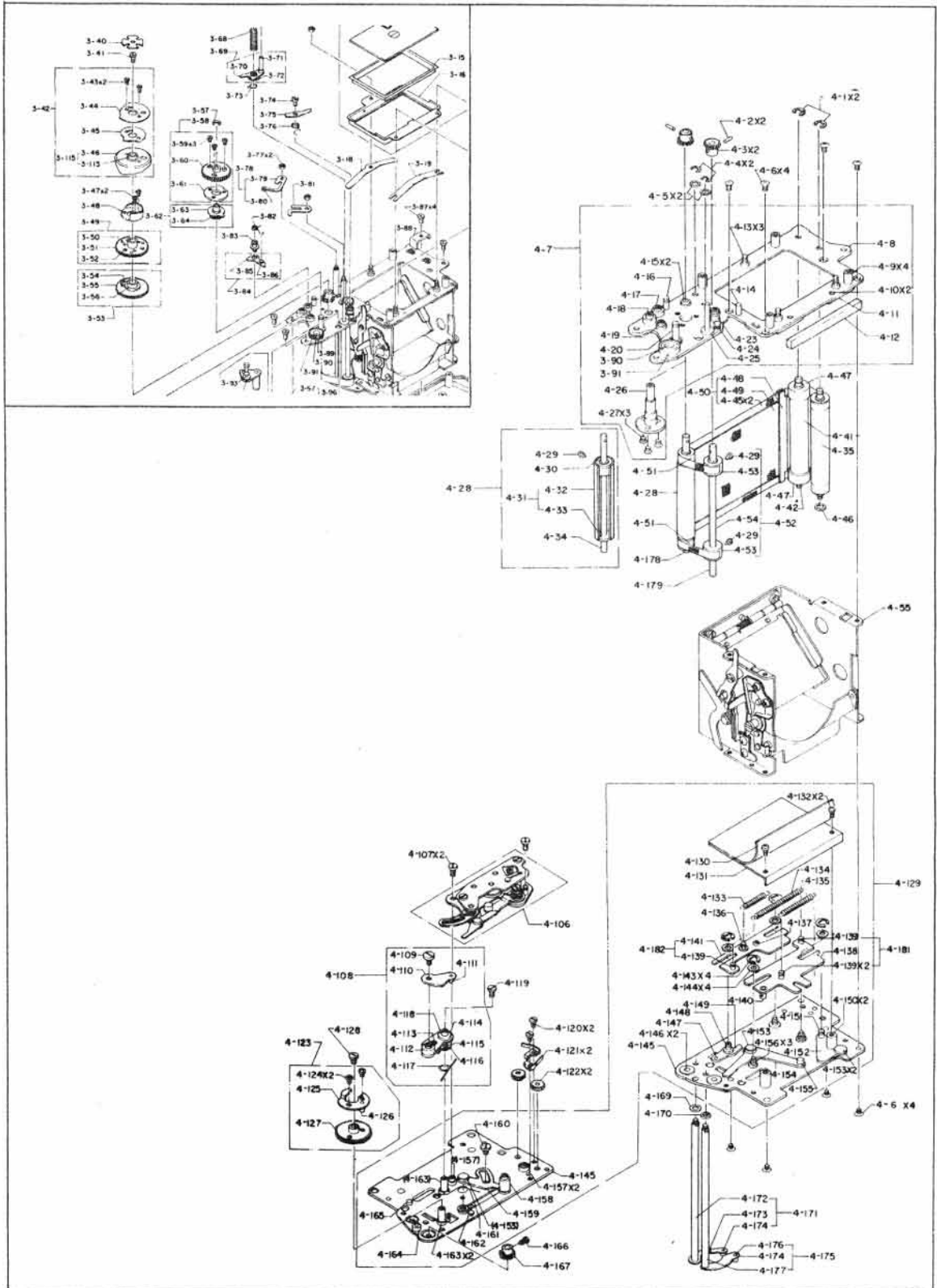


#### 14. DISASSEMBLING FOCAL PLANE SHUTTER ASSEMBLY

a. Shutter blind assembly

- 1) Remove two nuts (3-77) and remove the lever assembly (3-78) and cam lever (3-81).
- 2) Remove two E-clips (4-4), and remove the lower cam lever assembly (4-171) and lower lever assembly (4-175) carefully so as not to lose or damage the washers (4-5 (two), 4-169 and 4-170).
- 3) Remove the screw (3-41), and remove the shutter cam assembly (3-42) and 1st blind gear assembly (3-49).
- 4) Turn the screw (3-74) clockwise, and remove the claw (3-75).
- 5) Remove the screw (3-83), and remove the brake lever assembly (3-84).
- 6) Remove the 2nd blind gear assembly (3-53).
- 7) Remove two pins (4-2), and remove two gears (4-3).
- 8) Remove the screw (4-166), and remove the gear (4-167).
- 9) Remove two E-clips (4-1).
- 10) Hold shafts (4-36 and 4-42), and remove two ratchet wheels (4-122) by turning them clockwise.  
Remove two claws (4-121), and release the blind spring.
- 11) Remove four screws (4-6) in the shutter base plate assembly (4-7) side.
- 12) Separate the shutter base plate assembly (4-7) from the mirror box assembly (4-55).
- 13) Remove the shutter blind assembly carefully so as not to lose or damage the washer (4-46), two rollers (4-47) and two rollers (4-51).

Fig. 8



b. Quick return mechanism assembly (4-129)

When following 14-a-13) above:

- 1) Remove four screws (4-6).
- 2) Exercise care for the lead wire (4-77), and separate the quick return mechanism assembly from the mirror box assembly (4-55).
- 3) Remove two screws (4-132), and remove the cover (4-131).

When removing the quick return mechanism assembly (4-129) alone from the focal plane shutter assembly:

- 1) Remove the lower cam lever assembly (4-171) and lower lever assembly (4-175).
- 2) Remove two ratchet wheels (4-122).
- 3) Remove four screws (4-6), and remove the quick return mechanism assembly carefully so as not to lose the washer (4-46) and rollers (4-47 and 4-51).

c. Mirror assembly (4-94)

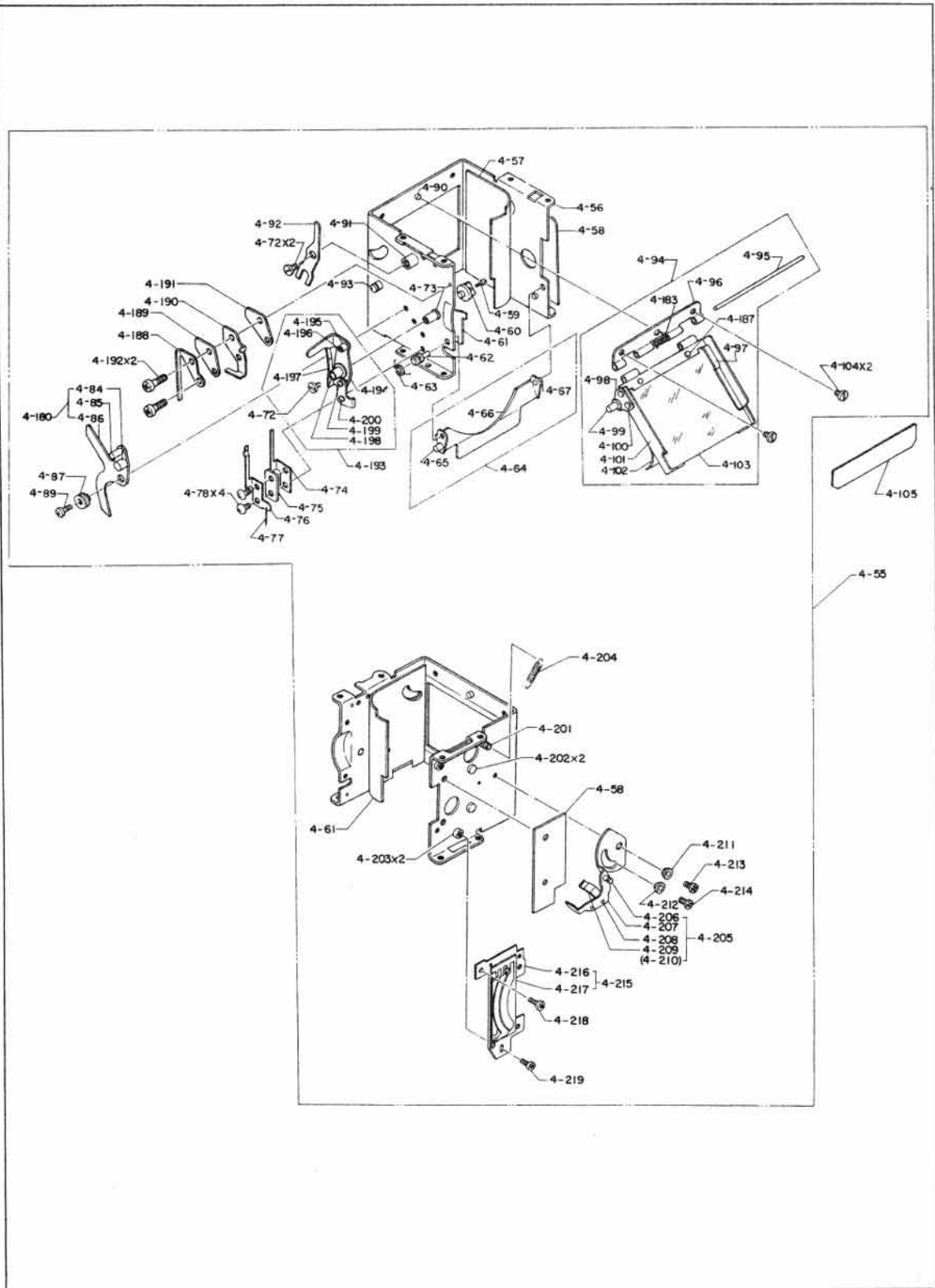
When removing the mirror assembly (4-94) alone from the lens mount assembly without disassembling the main body of the camera, the following instruction applies.

- 1) Remove the blind (4-105) from the mirror assembly by applying solvent to melt Pliobond.
- 2) Remove the screw (4-104).
- 3) Remove the mirror assembly (4-94) with a pair of tweezers carefully so as not to damage the mirror (4-103). Carefully remove the mirror assembly because the hinge (4-96) will move due to the spring (4-183).

d. Aperture resistor assembly (4-215)

- 1) Remove screw (4-218 and 4-219), and remove the connector (4-209) carefully so that it is not deformed.
- 2) When reassembling, be careful not to deform the connector (4-209).
- 3) It is ideal and desirable that the work be carried out with the rotary plate assembly (4-205) removed.

Fig. 9



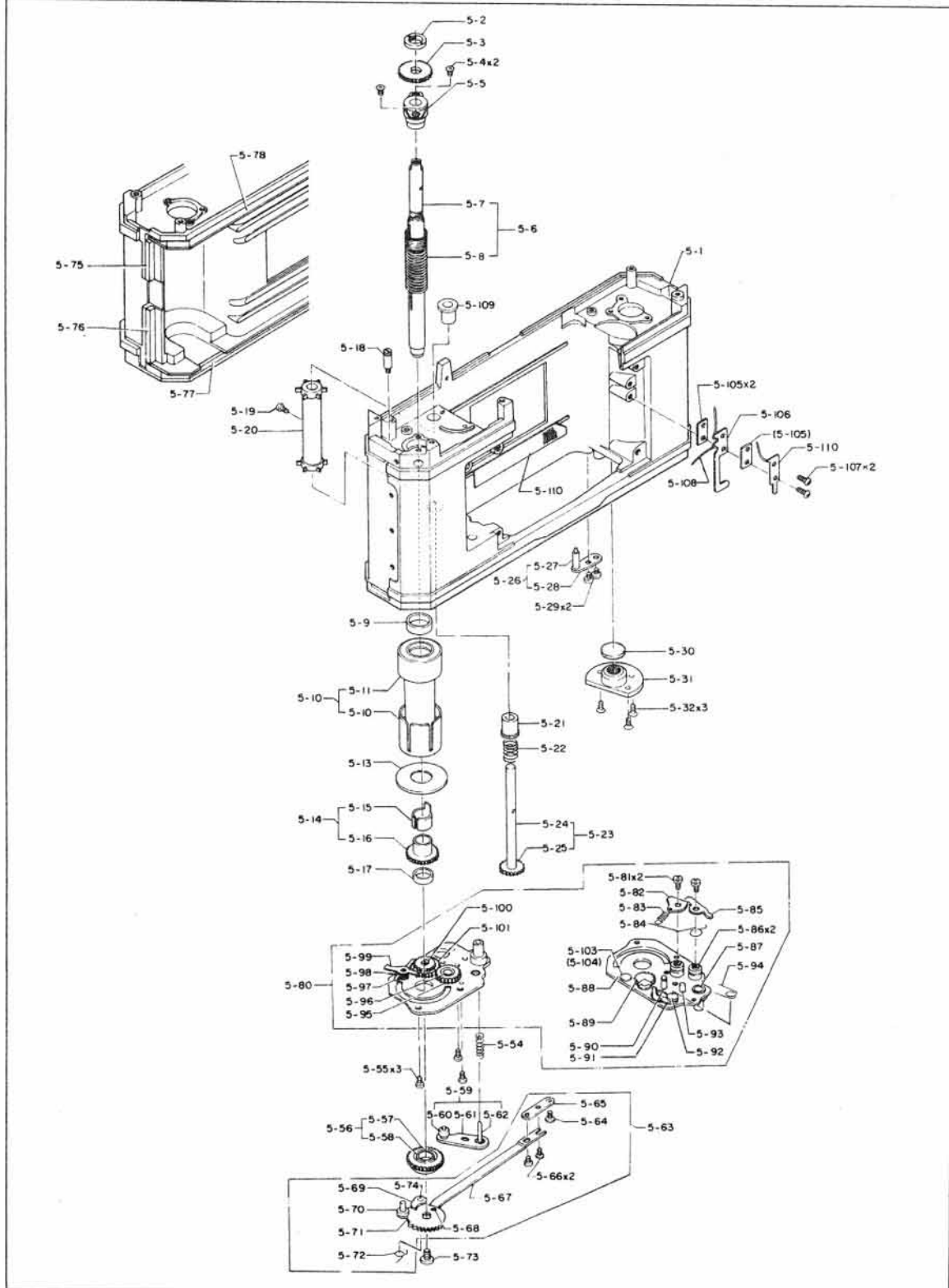
## 15. MAIN BODY ASSEMBLY

- a. Remove the screw (5-73), and remove the ratchet plate assembly (5-63) and ratchet wheel assembly (5-56).
- b. Remove three screws (5-55), and remove the base plate assembly (5-80).
- c. Remove the collar (5-17), spool gear assembly (5-14), washer (5-13), spool assembly (5-10) and bushing (5-9) in that order.
- d. Remove the ring (5-2), and remove the gear (5-3) from the spool shaft (5-7).
- e. Remove two screws (5-4), remove the holder (5-5), and remove the spool shaft assembly (5-6).
- f. Remove the screw (5-19), and remove the sprocket shaft assembly (5-23).
- g. Remove sleeves (5-21 and 5-109), and remove the sprocket (5-20).

NOTE: The sprocket (5-20) cannot be disassembled unless the sleeve (5-109) is removed.



Fig. 10



III.  
**REPAIR & ADJUSTMENT**

### III. REPAIR & ADJUSTMENT

#### 1. MAIN BODY ASSEMBLY

- a. Spring (5-8)
  - Make sure that the spring is lubricated with grease.
  - A silver colored spring has not been lubricated. Apply Helicolube/Molykote mixed grease.
  - Use of an unlubricated spring causes an abnormal sound to occur during film advancement.
- b. Ring (5-2)
  - The ring has to be tightened securely, and locked with Pliobond.
- c. Gears
  - All gears must have been lubricated with grease.
- d. Spool shaft assembly (5-6)
  - Place one end of the spring (5-8) into the groove on the holder (5-5).
  - Wind the spring two and a half turns toward the film advancing direction so that the spring is provided with a resetting force, and then, install ratchet plate (5-71) on the spool shaft assembly.
  - Make sure that the spool shaft is fitted into the square opening on the ratchet plate. If this fitting is too loose, film will not be advanced completely.



e. Friction of spool

Effective torque:  $330 \pm 50$  gr.

- Wind a piece of string around the circumference of the spool assembly (5-10), move the film advance lever, and measure slipping force.
- Adjust slipping between the friction plate (5-15) and gear (5-16).

NOTE: Apply Helicolube/Molykote mixed grease to the space between the friction plate (5-15) and gear (5-16) so that they are always lubricated. Lack of lubrication will cause abnormal film advancement.

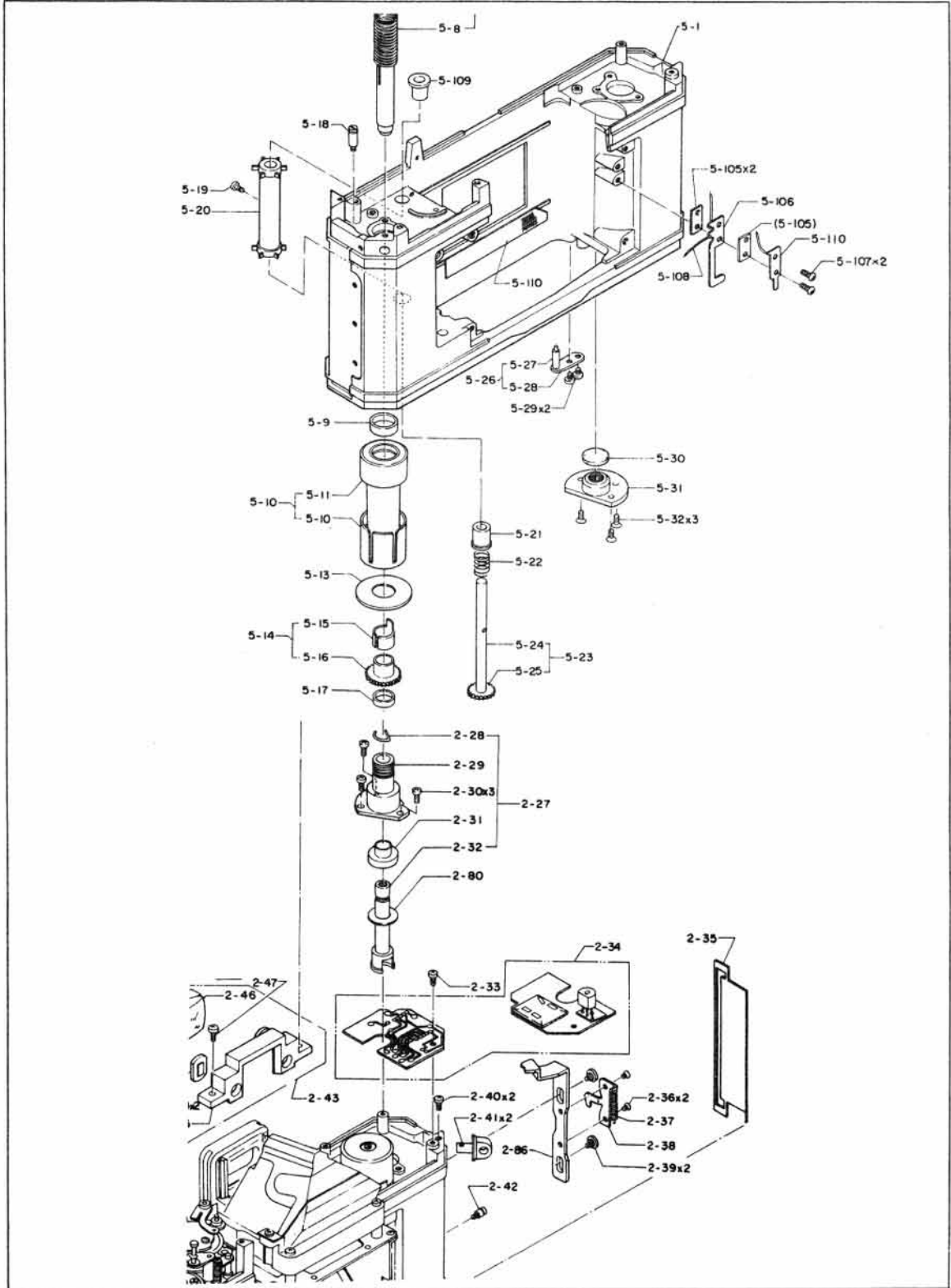
f. Sprocket (5-20)

- Depress the film rewind button assembly (5-59), and make sure that the lock effects causing the sprocket to be free.
- Make sure that the sprocket does not turn reversely when the film rewind button is unlocked and reset.

g. Rewind shaft assembly (2-27)

- Make sure that friction of the rewind shaft (2-32) is 15 to 50 gr-cm.
- Pull up the rewind shaft, and make sure that the back cover assembly (1-76) opens. At the same time, make sure that the base plate (2-111) is lifted and the pin (1-83) is disengaged from the plate (2-38).

Fig. 12



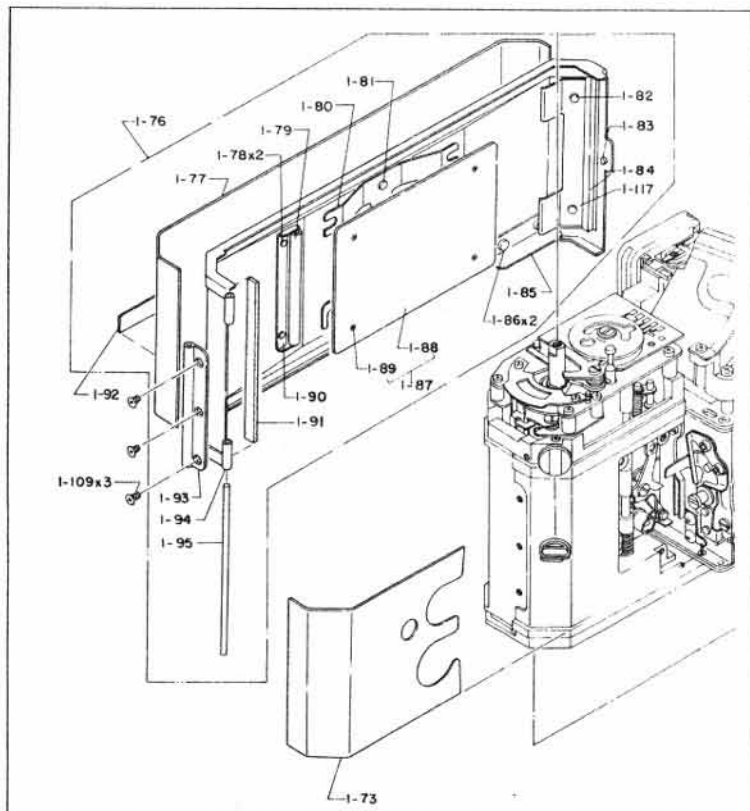
h. Back cover assembly (1-76)

- Make sure that the back cover has been securely installed on the main body with three screws (1-109) and that the back cover opens and closes smoothly.
- Make sure that the roller (1-79) and pressure plate (1-87) are not scarred or scratched, the roller turns smoothly, and that the pressure plate moves smoothly with the spring (1-80).

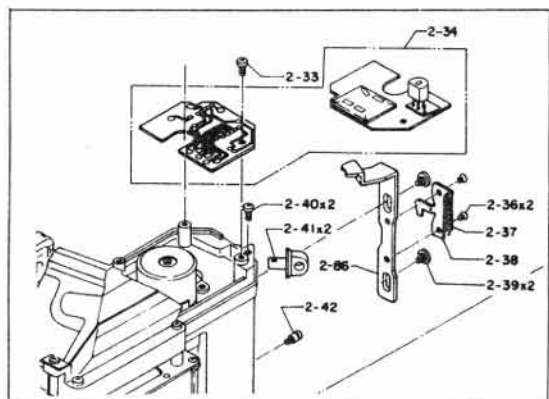
i. Neck strap ring (2-41)

Make sure that the neck strap ring has been securely tightened with the screw (2-40) and locked with Araldite.

**Fig. 13**



**Fig. 14**



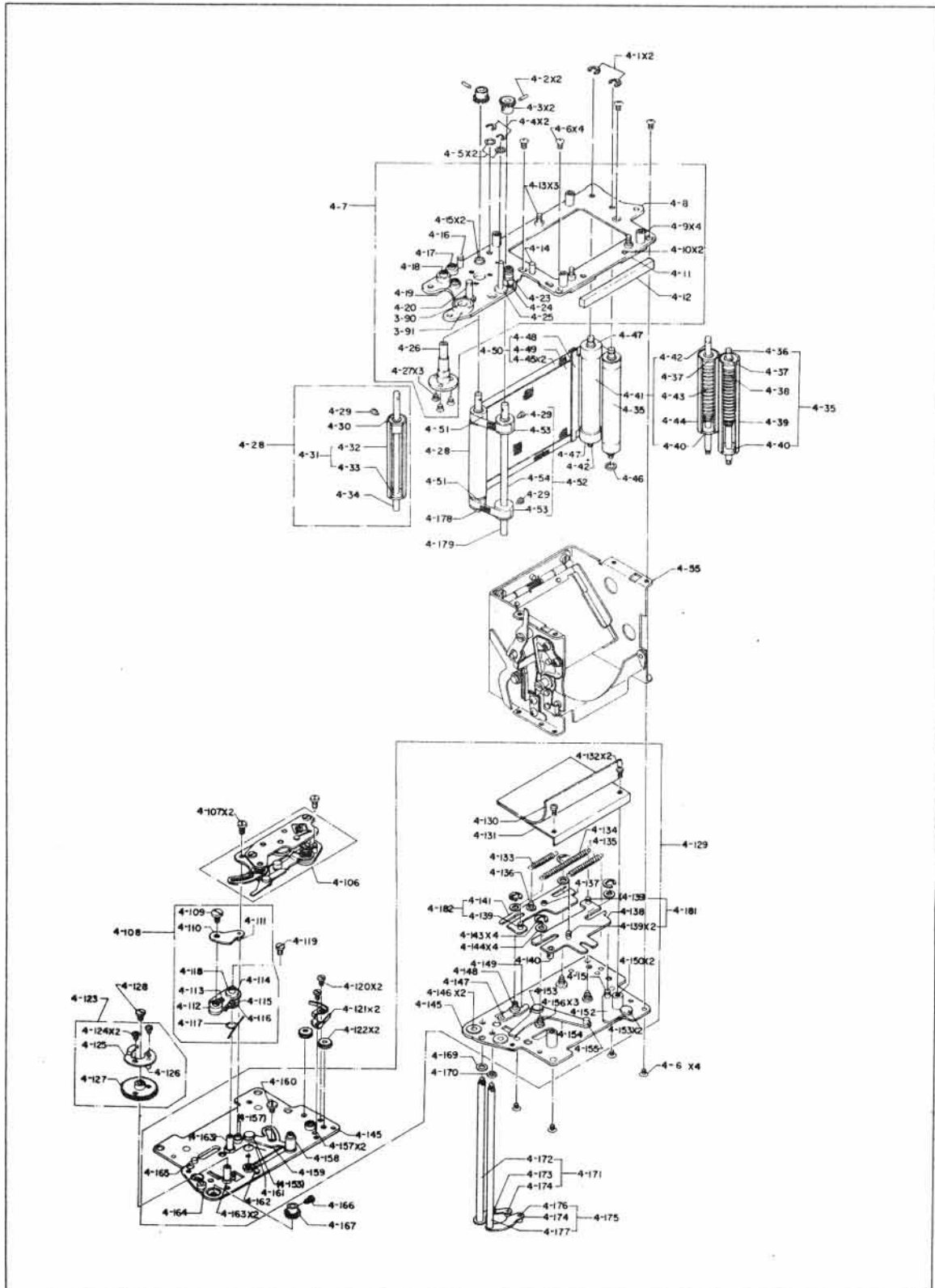


## 2. FOCAL PLANE SHUTTER ASSEMBLY

### a. Quick return mechanism assembly (4-129)

- Check each caulked part, and make sure that all of them are securely caulked.
- Apply Helicolube/Molykote mixed grease to the springs (4-133, 4-134 and 4-135) sufficiently to eliminate metallic sound generated by the springs.
- Make sure that the plate assemblies (4-181 and 4-182) are operated smoothly with the spring. Note that the plates may stop in a middle of the moving stroke when they are warped.
- Make sure that the hook lever (4-149) is operated smoothly with the spring (4-161). Do not use grease but slightly apply silicon oil #20 to the hook lever because existence of grease film between the hook lever and base plate (4-145) will not allow the hook lever to operate smoothly.  
Properly bend the hook lever (4-149) so that a gap is made in between the hook lever and base plate. When bending the hook lever, pay attention for limitation of height of the pin (4-147).
- Make sure that the hook lever (4-149) catches the pin (4-137) of the plate assembly (4-182) correctly.

Fig. 15



- b. Mirror box assembly (4-55) and quick return mechanism assembly (4-129)
- Hold the pin (4-140) of the plate assembly (4-181), set the quick return mechanism, release the pin from held condition, and make sure that the mirror assembly (4-94) rises smoothly.
  - Release the hook lever (4-149), and make sure that the mirror assembly (4-94) comes down smoothly.
  - Make sure that the hinge (4-96) and mirror shifter lever assembly (4-180) operate smoothly.
  - Make sure that the spring (4-183) is provided with a proper extra winding.
  - Make sure that the spring of the quick return mechanism assembly (4-129) has a sufficient spring force.

c. Shaft holders (two 4-146 and two 4-15)

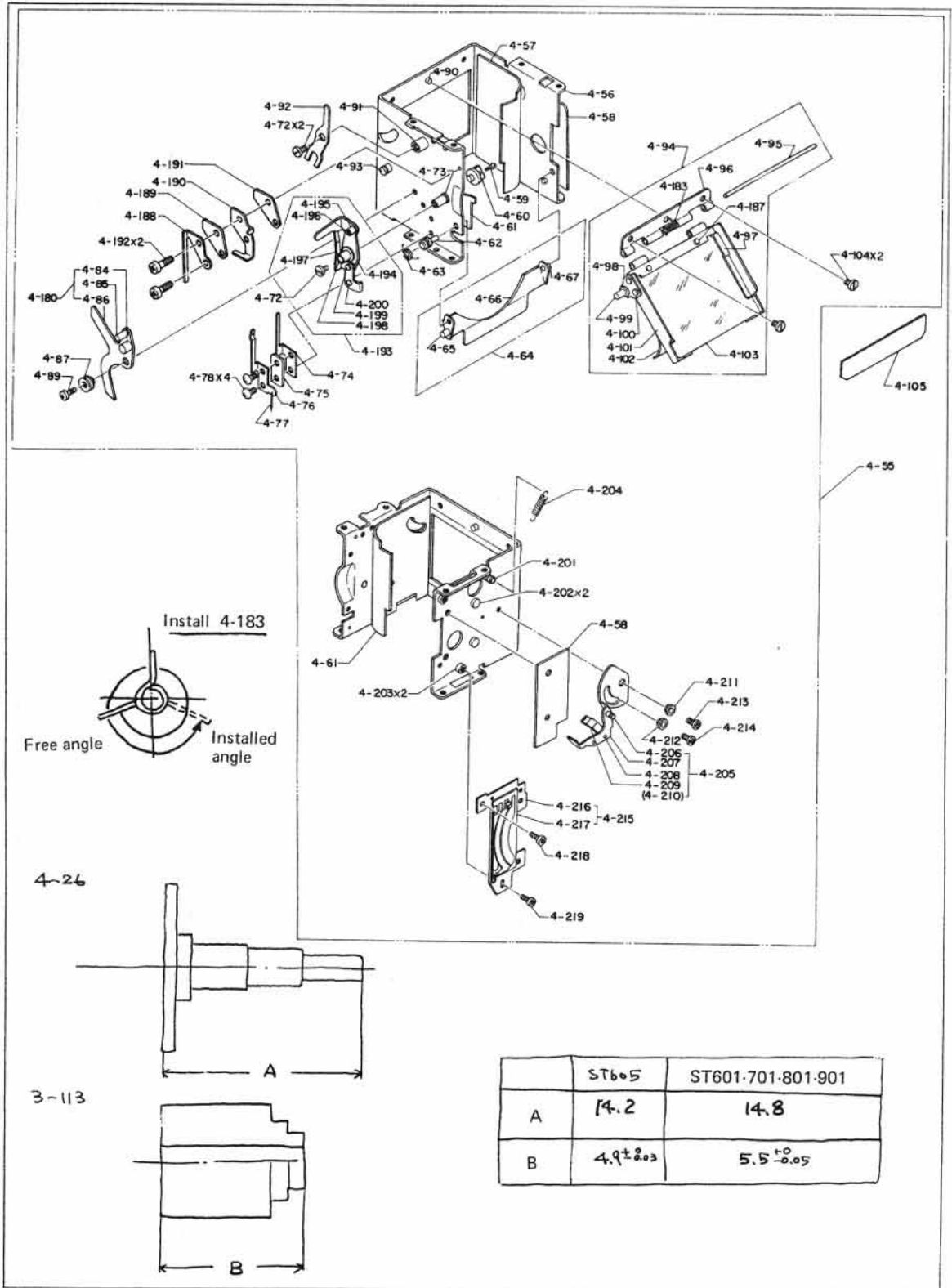
- Do not wash or clean these shaft holders because they are made of oil-less metal.
- Check them for lubrication, and slightly apply silicon oil #20 when needed.

NOTE: The following parts are similar to those for FUJICA ST601, ST701, ST801 or ST901, but cannot be used commonly because they are 0.6 mm shorter than others.

Shaft (4-26)

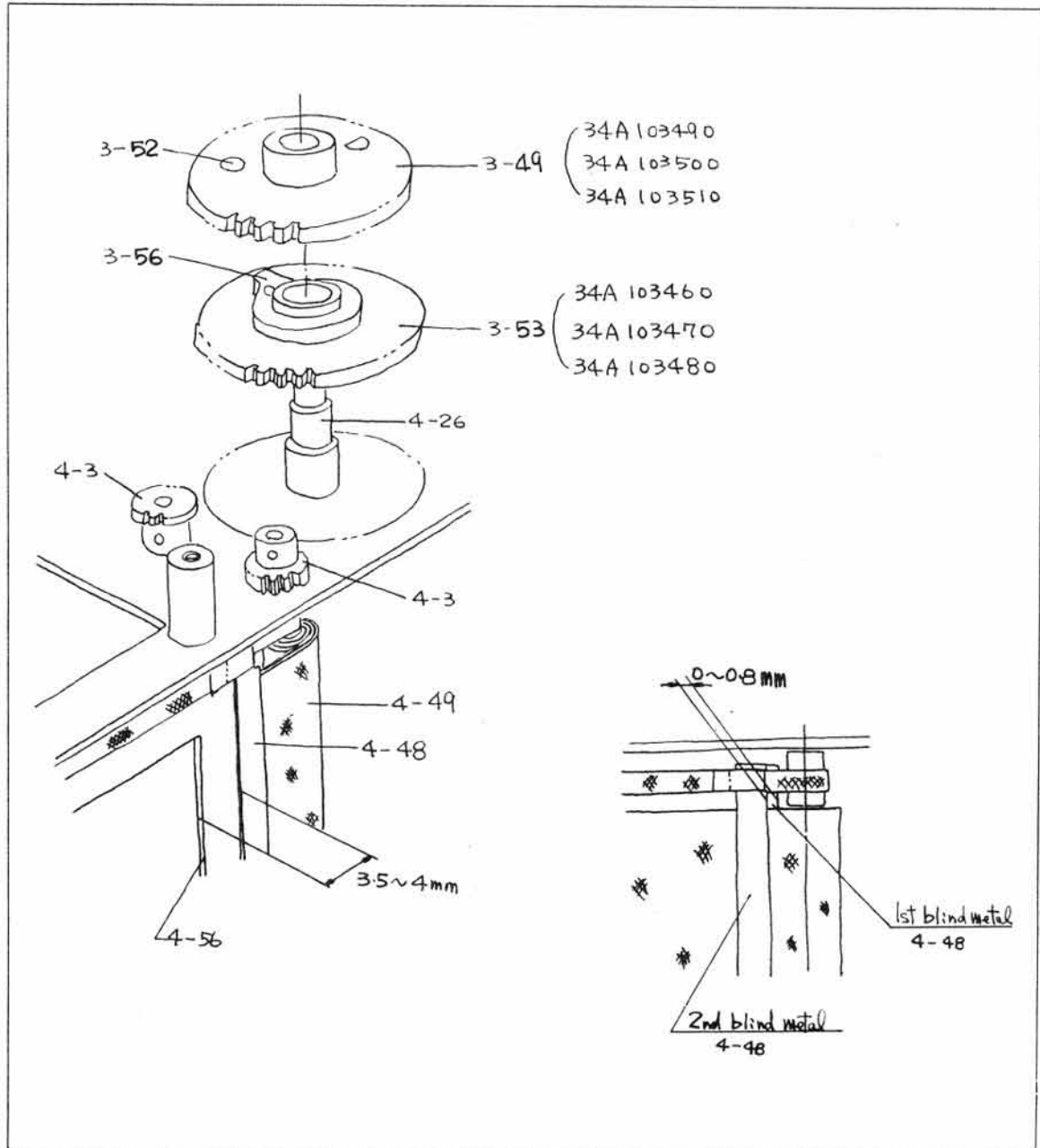
Bushing (3-113)

Fig. 16



- d. Adjusting positions of the 1st and 2nd blinds
- 1) Position of 2nd blind
    - Adjust gap between the wall of the mirror box (4-56) and end of the fixture (4-48) to 3.5 to 4.0 mm.
    - With the stopper lever (3-73) engaged with the hook plate (3-56), replace the 2nd blind gear assembly (3-53) with one of another size, and adjust the gap.
  - 2) Position of 1st blind
    - Match the 1st blind fixture with the 2nd blind fixture, and adjust the gap shown in Fig. 17 to 0 to 0.8 mm. (It may be adjusted to 0 to 1.5 mm, if no other part is affected.)
    - With the claw (3-75) engaged with the pin (3-52), replace the 1st blind gear assembly (3-49) with one of another size, and adjust the gap.
  - 3) At the time of adjustment, make sure that the 1st and 2nd blinds are provided respectively with 3-1/2 and 1-1/2 turns of extra windings.

Fig. 17



- e. Installing focal plane shutter assembly
- 1) Installing focal plane shutter assembly on the main body assembly
    - Set the shutter blinds to positions at which the blinds are wound up completely.
    - Place the focal plane shutter assembly onto the main body assembly slowly and carefully.
    - Fit the pin (4-164) into the opening on the base plate assembly (5-80).
    - Tighten four screws (3-87).
    - Install the positioning plate assembly (5-26).
    - Make sure that there is a proper gap between the base plate (4-145) and the main body interior, and thus, make sure that the shutter blinds are not in contact with the body proper (5-1).
  - 2) Installing lever (3-104) and brake lever (3-106)
    - Apply Helicolube/Molykote mixed grease to the shaft portions and sliding surfaces of these levers.
    - Tighten the screw (3-107) securely.
  - 3) Gear assembly (4-123)
    - Install the gear assembly (4-123) in parallel with the body as shown in Fig. 19.
    - Apply silicon oil #20 to the shaft portion slightly.

Fig. 18

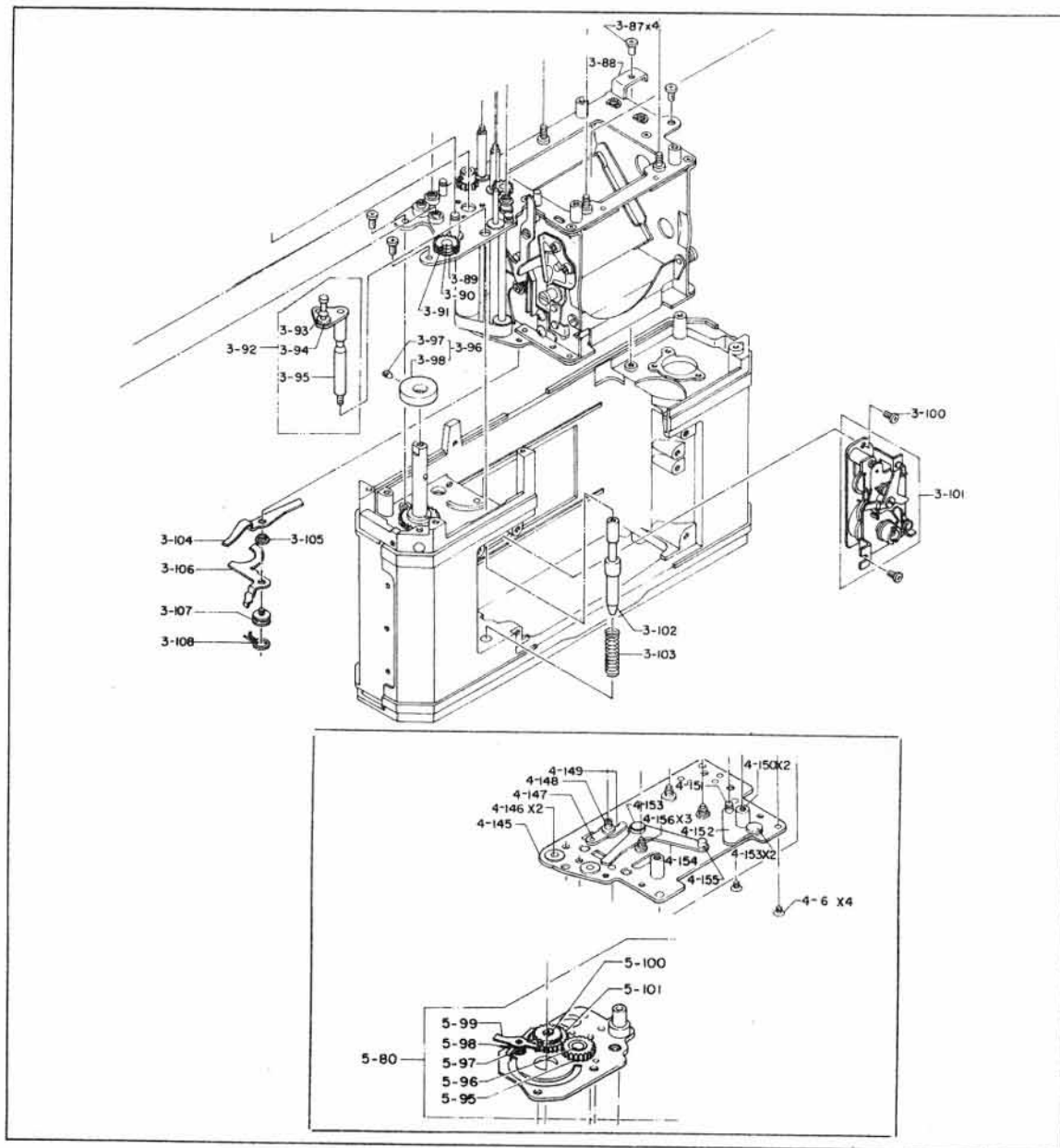
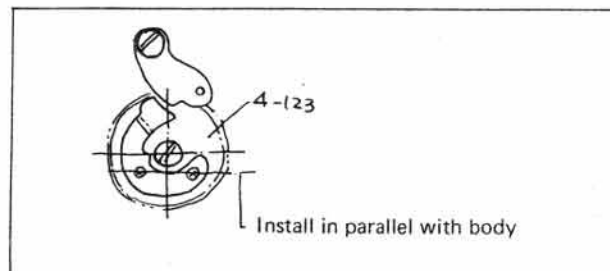


Fig. 19

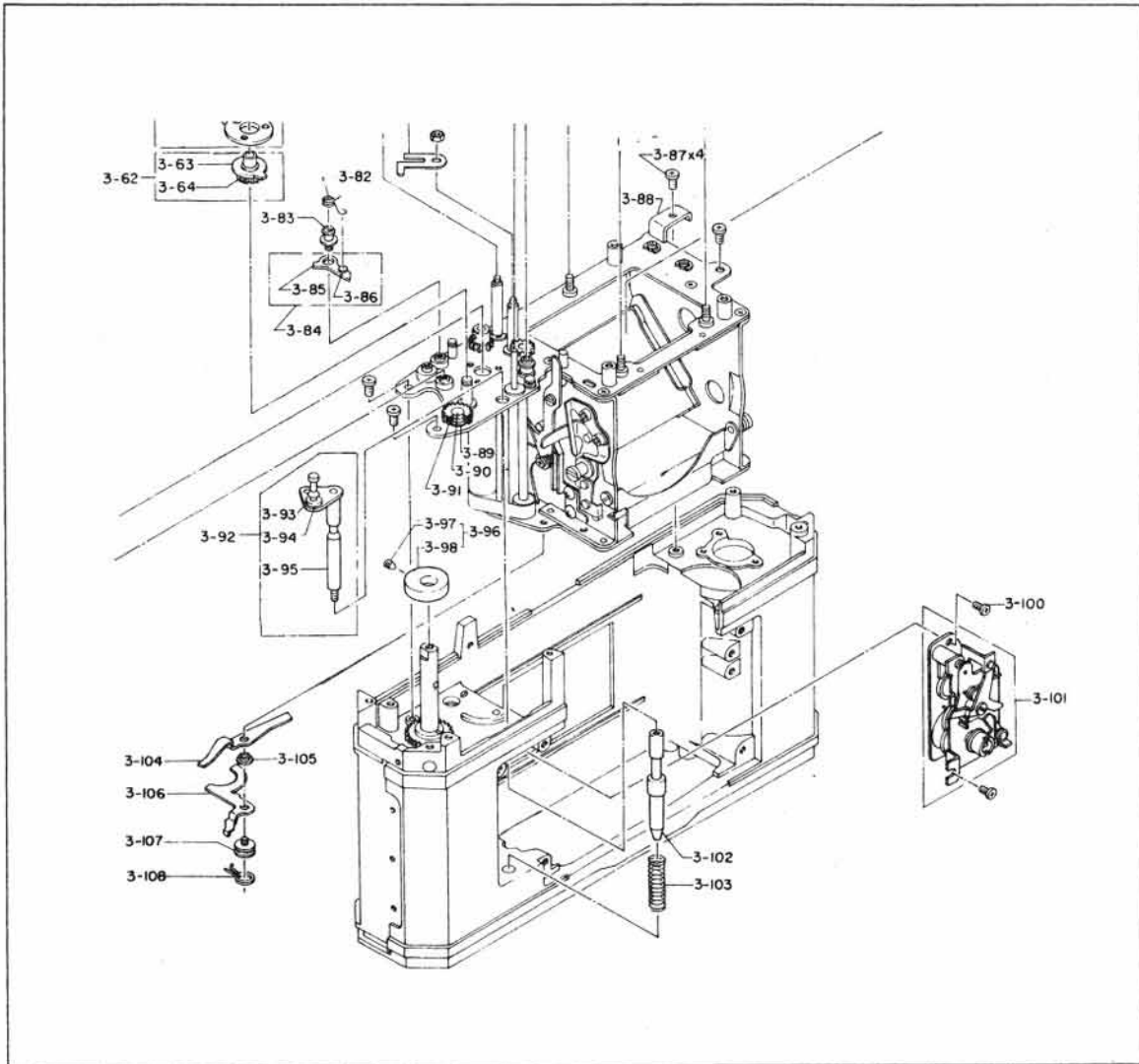




- 4) Self-timer assembly (3-101), shutter release shaft assembly (3-92) and release shaft (3-102)
- Place the self-timer assembly in its position, and insert the spring (3-103) and release shaft (3-102) into the opening on the main body of the camera.
  - Insert the shutter release shaft assembly (3-92) into the camera body from the top of the camera body, and after applying Pliobond to the threaded portion, tighten the threaded portion.
  - Tighten two screws (3-100) carefully so as not to lose them.

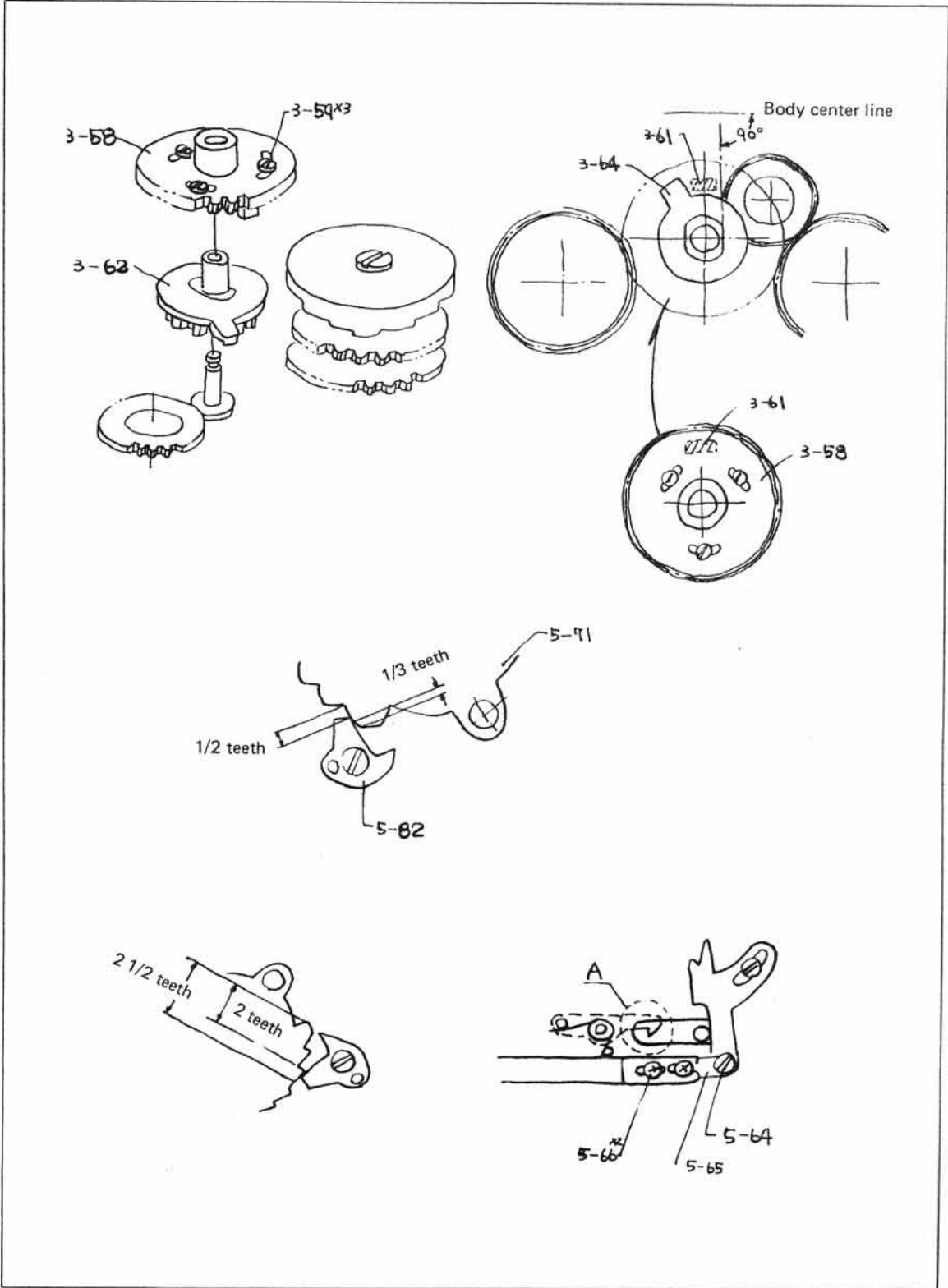
NOTE: Carry out the above works without setting the quick return mechanism. When the quick return mechanism is set completely and the release shaft is depressed, the shutter will operate.

Fig. 20



- 5) Adjusting shutter blind setting position (Installing clutch plate assembly (3-58) and clutch gear assembly (3-62))
  - Set the shutter blinds to the positions where the shutter blinds are wound up completely.
  - Set the spool shaft (5-7) to its returned position.
  - Install the clutch gear assembly (3-62) in the position.
  - Install the clutch plate assembly (3-58) in the position after adjusting position of the clutch plate assembly (3-58) so that three screws (3-59) are in the centers of the long openings on the clutch plate assembly.
  - Apply the silicon oil #20 to the shaft portion slightly.
  - Tighten four screws (5-64) and join the connecting plate (5-65) and connecting shaft (4-158).
  - Wind up the film advance lever, check the relative positions of the ratchet plate (5-71) and lever (5-82), and check the position where the shutter blinds are wound up completely. (1/3 to 1/2 of the gear tooth)
  - Loosen the screws (3-59), and adjust positions of the clutch gear (3-60) and clutch plate (3-61). Lock the screws with Pliobond after completing the adjustment.
- 6) Adjusting set position of the quick return mechanism.
  - Wind up the film advance lever, check the relative positions of the ratchet plate (5-71) and lever (5-82), and check the set position (engaging position shown as "A" in Fig. 21) of the quick return mechanism assembly. (2 to 2-1/2 teeth)
  - Loosen two screws (5-66), and adjust length of the connecting plate (5-65) and length of the lever (5-67). Lock the screws with Pliobond after completing the adjustment.

Fig. 21



f. Shutter release

- 1) Make sure that shutter releasing load is 500 gr. or less.
- 2) Make sure that the release shaft can be depressed 0.2 mm or more after releasing the shutter. When adjusting, properly bend the portion shown as "A".
- 3) Make sure that the shutter can be released with the self-timer.
  - Make sure that the shutter releases when the self-timer operates for about 10 seconds and that the self-timer continuously operates for a while after the shutter release. When adjustment is needed, properly bend the portion shown as "B".

g. Adjusting shutter speed

- 1) Adjustment of shutter blind traveling velocity
  - The rated shutter blind traveling velocity is 12 msec. (Time within which the shutter blind travels on the 32 mm slit of a tester)
  - Make sure that difference of traveling velocity between the 1st and 2nd blinds is within 0.2 msec. (It is desired that the 2nd blind is slower than the 1st blind.)
  - When adjusting shutter blind traveling velocity, set the cam to 1/1500 sec.
  - Note that shutter blind traveling speed increases as the 1st blind shaft (4-36) and 2nd blind shaft (4-42) are turned toward the direction indicated by the arrow mark.
- 2) Adjustment of kick lever assembly (3-65)
  - Set the shutter, depress the shutter release lever, and make sure that the kick lever enters beyond the position shown in Fig. 23 first, and then the shutter releases. When this condition is unsatisfactory, replace the stopper lever assembly (3-69) with a new one.
  - Set up and release the shutter two to three times, and make sure that the kick lever operates normally
  - Set shutter speed to 1/1500 sec., and adjust height of the kick lever assembly (3-65) against the cam (3-48) to 0 to 0.2 mm.  
When adjustment is needed, properly bend the kick lever.  
Note that when this adjustment is improper, shutter speed may be deviated to the adjacent shutter speed of a selected shutter speed depending upon a posture of the camera.

Fig. 22

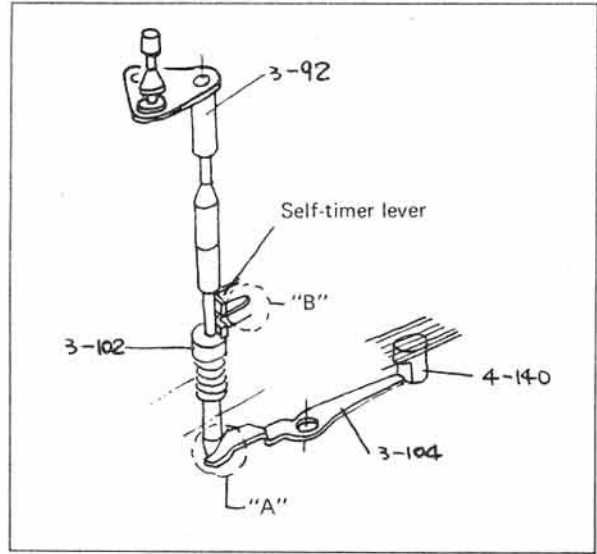
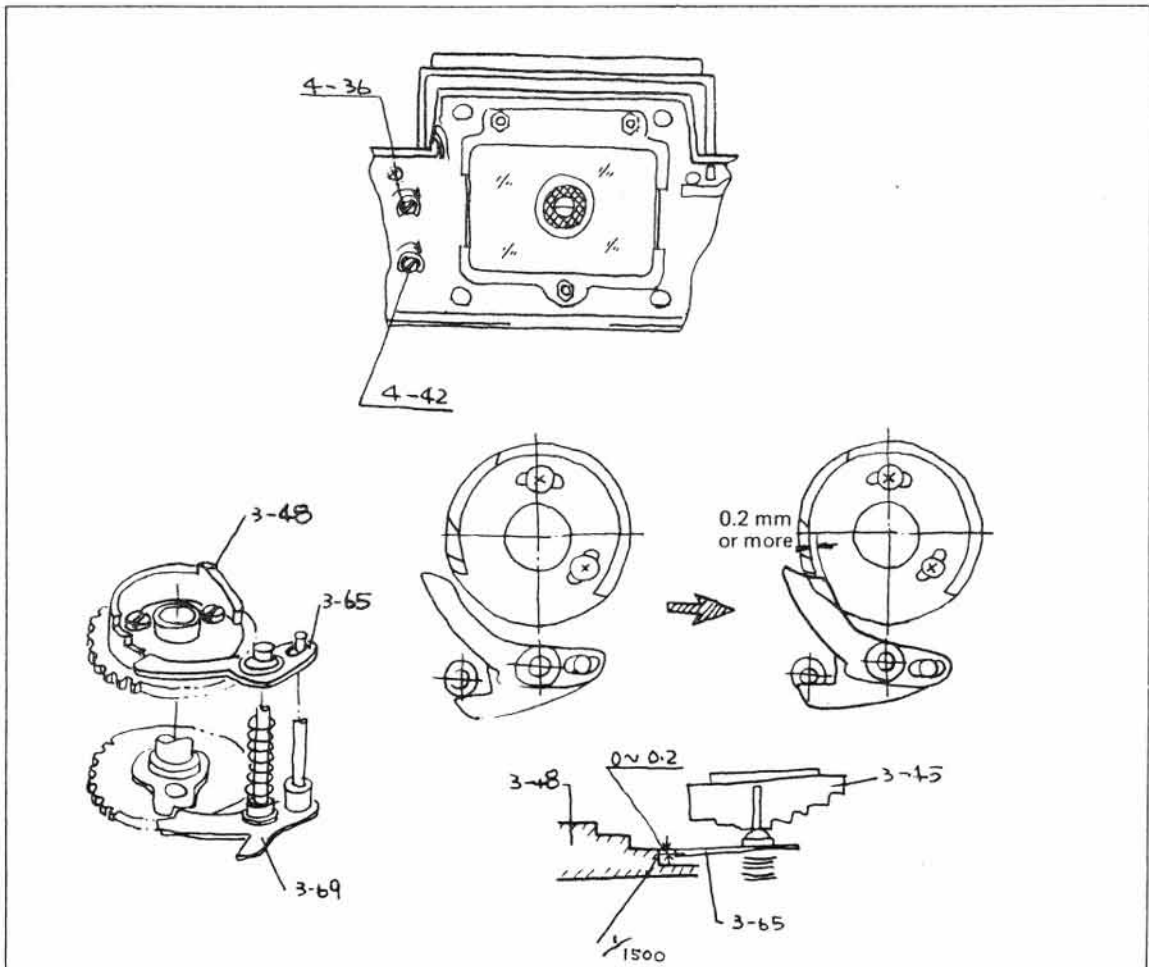


Fig. 23



3) Adjustments of shutter speeds 1/1500 through 1/60 sec.

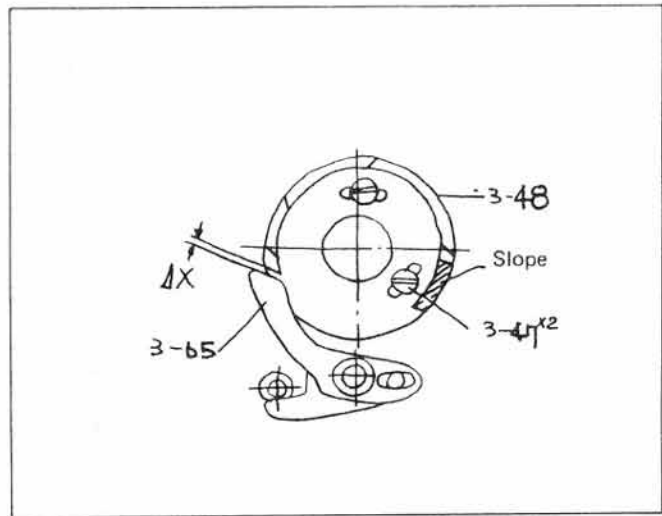
- Make sure that the shutter blind traveling velocity is correct (12 msec.), and difference of traveling velocity between the 1st and 2nd blinds is within 0.2 msec.
- Take a proper action so that the governor assembly (4-106) does not operate.
- Change position of the cam (3-48), and repeat adjustments so that the 1/1500 sec. shutter speed is in the center value of the rated shutter speed.
- Make sure that shutter speeds 1/1000 sec., 1/500 sec., 1/250 sec., 1/125 sec., and 1/60 sec. are within the ratings.

When the rated shutter speed cannot be obtained, replace the cam (3-48) with a new one.

Note that the cam (3-48) for ST705 is provided with a slop as seen in Fig. 24 so that it can be easily discriminated from that for ST801.

- When shortening shutter speed, reduce gap  $\Delta X$ .
- When extending shutter speed, increase gap  $\Delta X$ .
- When the adjustment is completed, be sure to lock the two screws (3-47) with screw locking agent.
- Apply silicon oil #20 to the shaft portion slightly.

Fig. 24



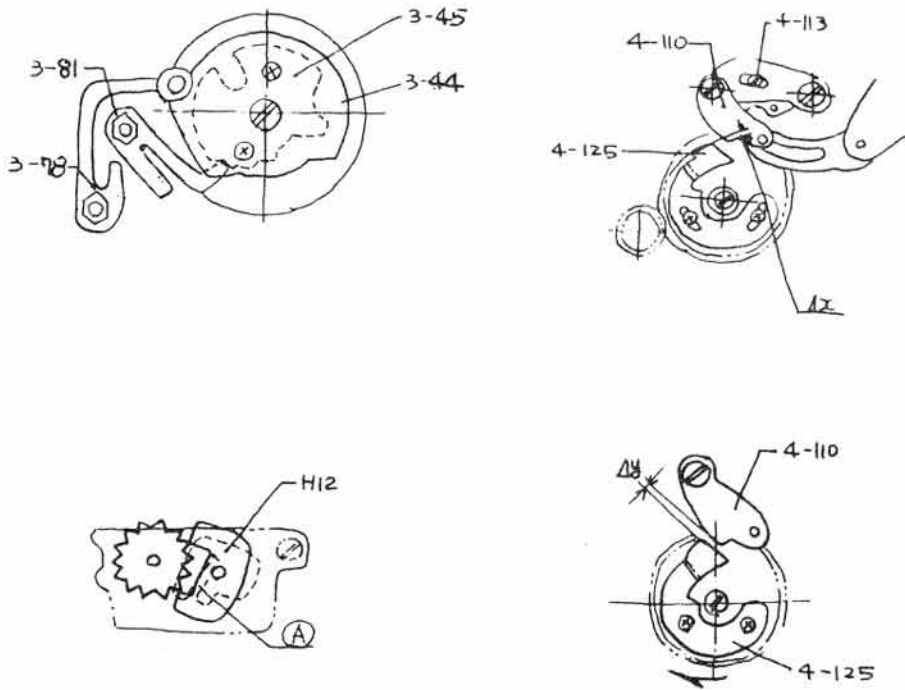
Unit of measure: msec.

Shutter speed	Rating within which adjusted	Rating for inspection	Rating for export inspection
1/1500	0.45 - 0.80	0.44 - 0.88	0.27 - 1.05
1/1000	0.74 - 1.29	0.65 - 1.37	0.58 - 1.64
1/500		1.43 - 2.67	1.16 - 3.28
1/250		2.86 - 5.34	2.32 - 6.57
1/125		5.92 - 10.7	4.65 - 13.1
1/60		11.4 - 21.3	11.0 - 22.1



- 4) Adjustment of shutter speed (from 1/30 sec. to 1 sec.)
- Install the cam lever (3-81) and lever (3-78) as shown in Fig. 25.
  - Properly bend the cam lever (3-81) so that lever (4-110) and claw plate (4-125) are not in contact at shutter speeds (from 1/1500 to 1/60 sec.).
  - Set the shutter speed selector dial to 1/30 sec.
  - Adjust the eccentric pin (4-113) repeatedly until shutter speed (1/30 sec.) is within the rating.  
Shutter speed is extended as gap  $\Delta X$  is increased.  
When shutter speed (1/30 sec.) cannot be adjusted with eccentric pin (4-113), readjust the cam lever (3-33).
  - Check shutter speeds (from 1/15 to 1 sec.)
  - Adjustments of shutter speeds 1/4 and 1 sec.  
Properly bend portion "A" to adjust engagement of ankle (H12) of the governor assembly.  
Adjust position of the claw plate (4-125).  
NOTE: When the claw plate position is adjusted, readjust shutter speed 1/30 sec.
  - Adjustments of shutter speeds 1/15 and 1/8 sec.  
Adjust these shutter speeds by adjusting position of the claw plate (4-125).  
Gap  $\Delta Y$  should be 0.3 mm or more. In this case, however, the claw plate (4-125) should not come into contact with the lever (4-110) even if the claw plate (4-125) is depressed in as much as the backlash of the gear.
  - Repeat the above described adjustments until all shutter speeds are within the ratings.

Fig. 25



Unit of measure: msec.

Shutter speed	Rating within which adjusted	Rating for inspection	Rating for export inspection
1/30	32 - 38	25 - 41.6	22.1 - 44.2
1/15		50 - 83.4	44.2 - 88.4
1/8	100 - 156	93.8 - 156	88.4 - 177
1/4		188 - 313	177 - 354
1/2		375 - 625	354 - 707
1/1		732 - 1366	644 - 1366

5) Checking "B" (Bulb)

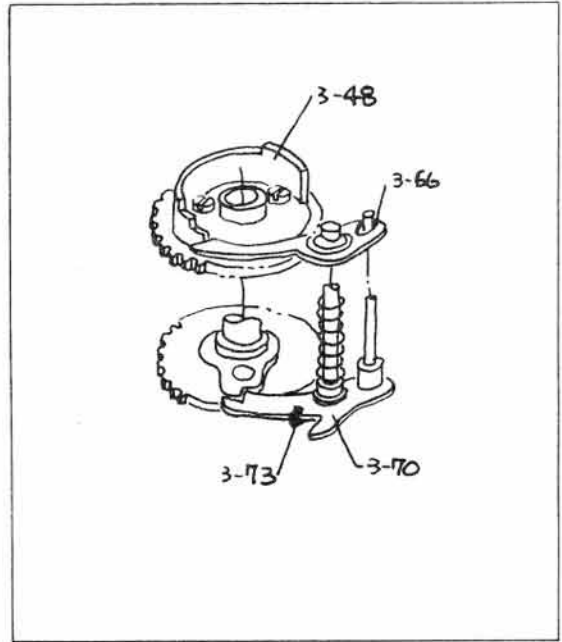
- Set the shutter speed selector dial to "B", and make sure that the shutter blind fully opens.
- When the shutter blind does not fully open, check the stopper lever (3-70) for deformation, spring (3-73) for unhooking, and check releasing point and timing of the stopper lever operation.
- Note that when heights of the cam (3-48) and kick lever assembly (3-66) are abnormal, shutter blind will fully open (shutter opens in "Bulb") with the shutter speed selector dial set to "1/60".

6) Exposure fluctuation

Exposure fluctuation is a problem especially at high shutter speeds (1/1500 sec. through 1/500 sec.).

Fluctuations of 1st and 2nd shutter blind traveling velocities cause exposure fluctuations. When fluctuations of 1st and 2nd shutter blind traveling velocities exceed the ratings, check the shutter blind and the related parts, and replace the shutter blind assembly with a new one as required.

Fig. 26



7) Bound of shutter blind

The shutter blind may bound at the end of its travel and come back into the picture frame. Bound of shutter blind affects exposure especially at a high shutter speed.

Bound of 1st blind: Causes an under-exposure in as much as the 1st blind bounds.

Bound of 2nd blind: Causes an over-exposure in as much as the 2nd blind bounds.

- Bound of 1st blind

Deformation of the spring (3-38) causes the 1st blind to bound.

Replace it with a new one.

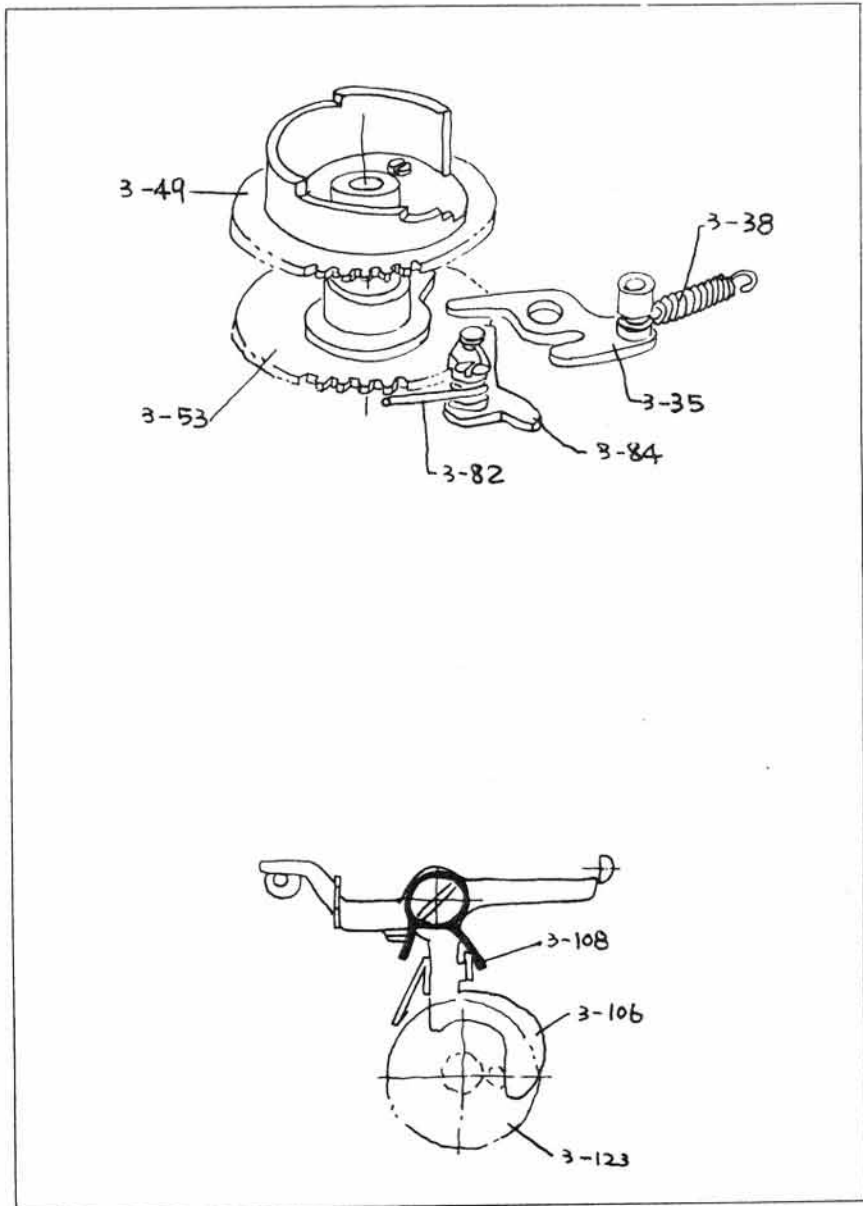
- Bound of 2nd blind

Deformation of the spring (3-108) causes the 2nd blind to bound.

Replace it with a new one.

- When bound of shutter blind cannot be repaired by replacing the spring, replace the brake assembly (3-35), brake lever assembly (3-84), spring (3-82), brake lever (3-106) and gear assembly (4-123) with new ones.

Fig. 27



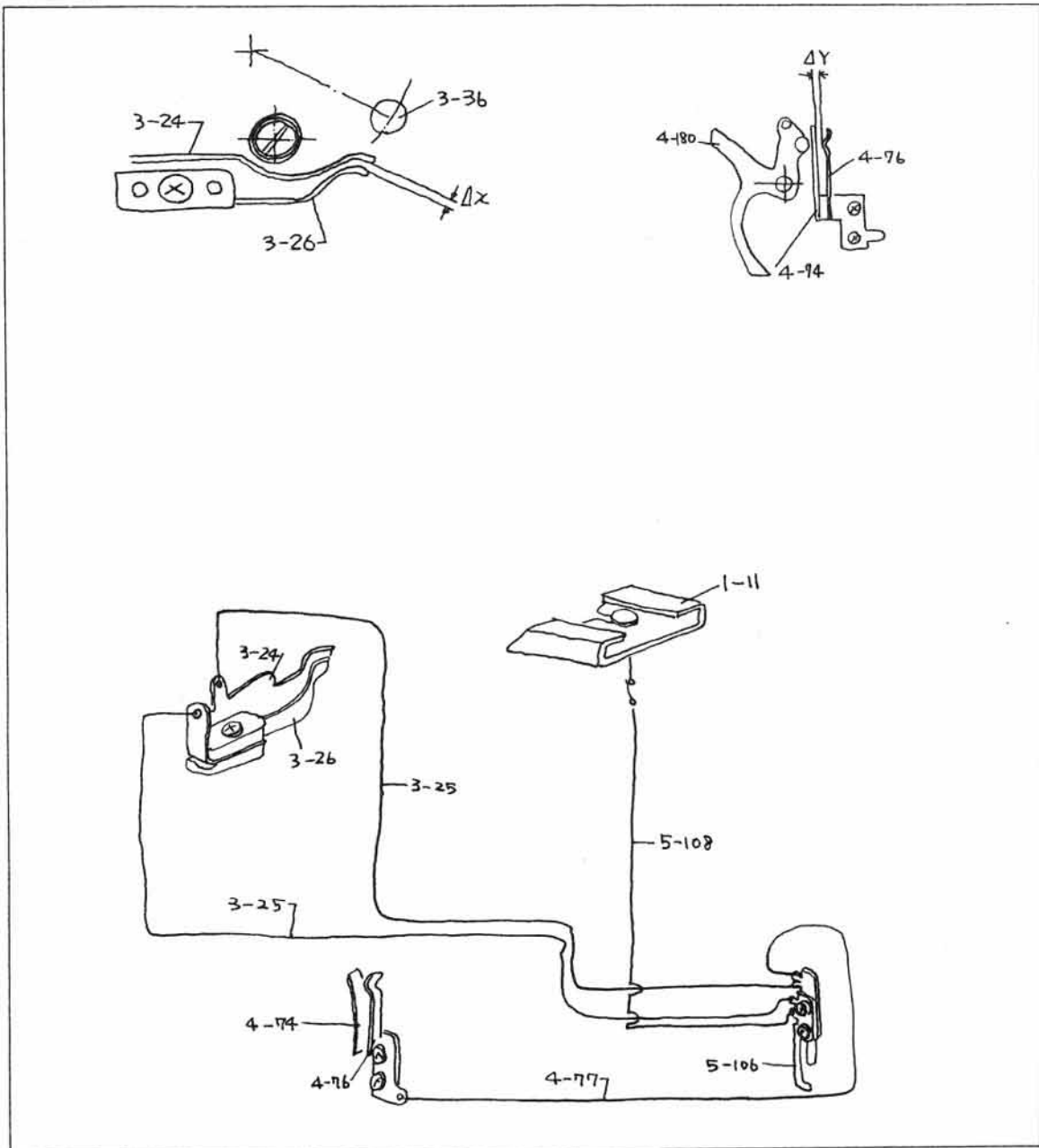
8) Synchro-delay time

X-contact 0.6 to 1.5 msec.

FP-contact 9 to 12 msec.

For adjustment of synchro-delay time at X or FP-contact, adjust  $\Delta X$  or  $\Delta Y$ .

Fig. 28





9) Shutter and quick return mechanism assembly

Fig. 29 shows the shutter and quick return mechanism assembly completely set.

- Quick return mechanism assembly

Make sure that the rocker arm (4-149) has been engaged with the pin (4-136) correctly.

Make sure that the end of the brake lever (3-104) has been correctly engaged with the hook on the column (4-140).

- Shutter assembly

Make sure that the claw (3-75) has been correctly engaged with the hook pin of the 1st blind gear assembly (3-49).

- Make sure that the various levers operate smoothly and that they are properly lubricated with the oil and grease specified below:

Silicon oil #20: For shaft holding portions of 1st blind gear assembly (3-49), 2nd blind gear assembly (3-53), stopper lever assembly (3-69), kick lever assembly (3-65), clutch plate assembly (3-58), and gear assembly (4-123).

Helicolube/Molykote mixed grease:

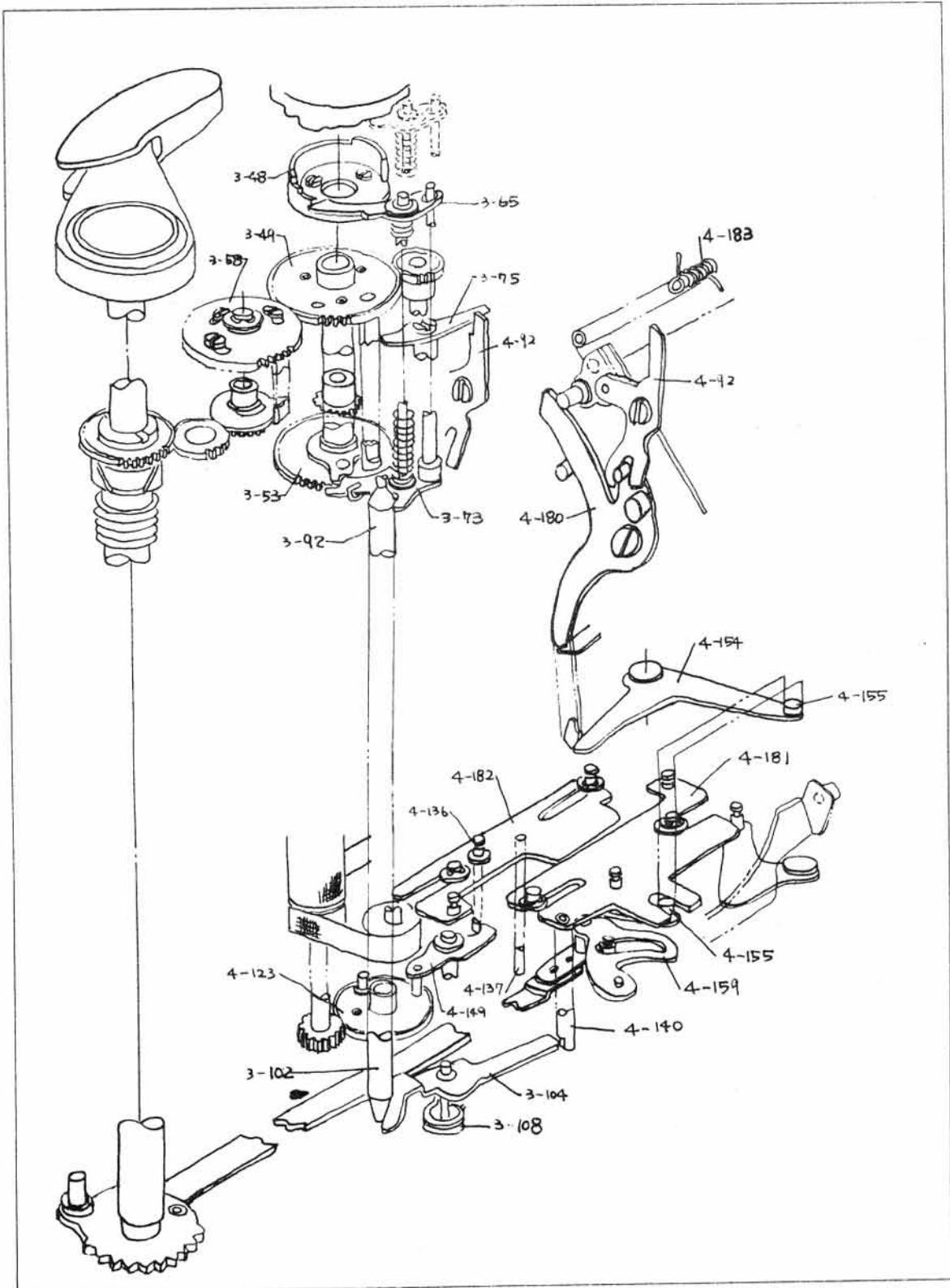
For sliding surfaces and shaft holding portions of brake lever (3-104), plate assembly (4-181), plate assembly (4-182), lever (4-154), mirror shifter lever assembly (4-180), and plate (4-159).

- When the shutter and quick return mechanism assembly complete their operations: The mirror assembly (4-94) must have been reset to the 45° stopper by the spring (4-183).

The plate assembly (4-181) must have returned to the original position, and the brake lever (3-104) and column (4-140) must have been engaged. When these conditions are abnormal and the film advance lever is wound up, the mirror goes up and will not come down.

The rocker arm (4-149) must have been unhooked by the gear assembly (4-123).

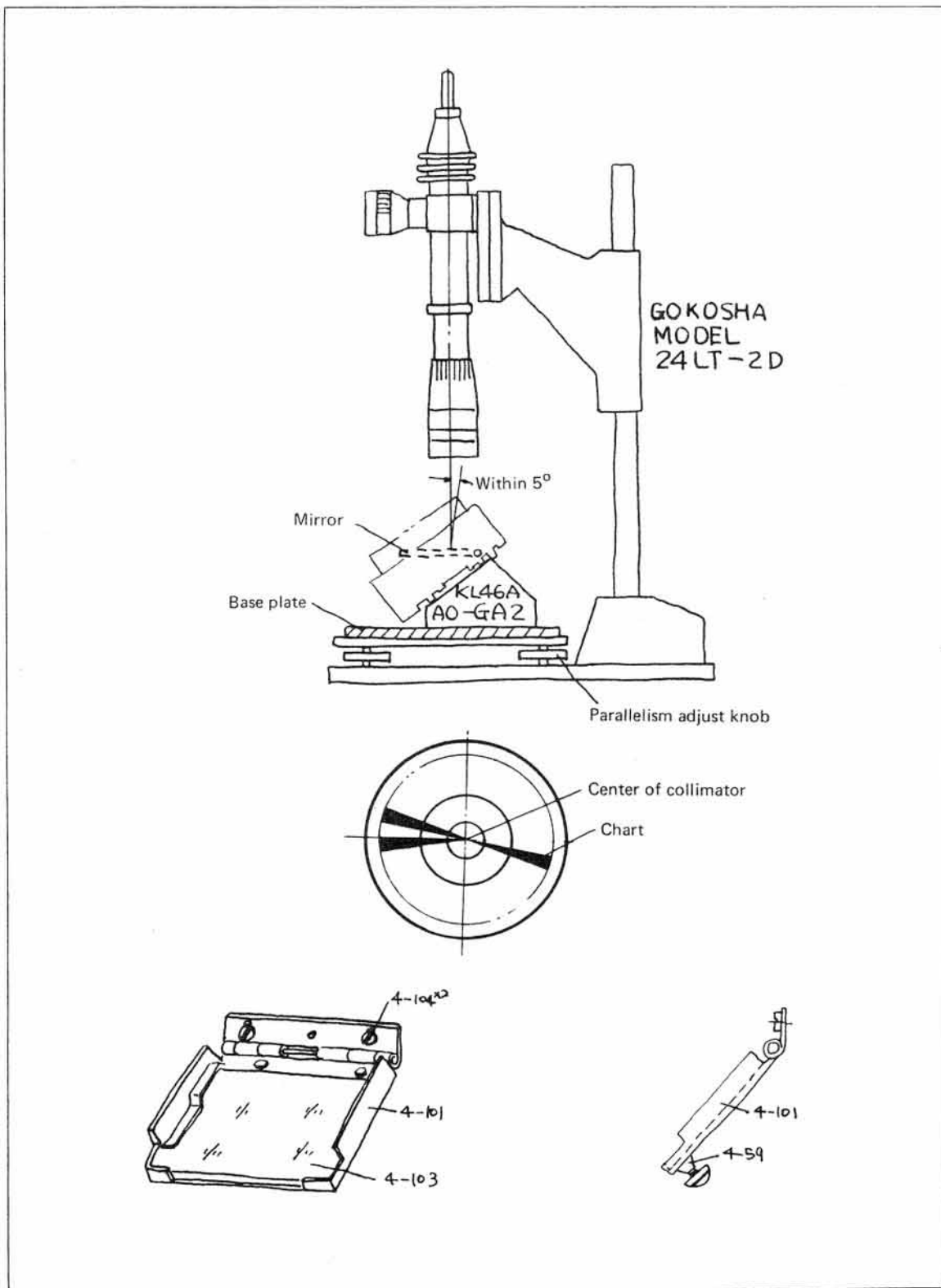
Fig. 29



### 3. ADJUSTMENT OF 45° ALIGNMENT OF THE MIRROR

- Adjust parallelism of the base plate of the collimator (Gokosha Model 24LT-2D).
- Mount the camera on a special tool (KL46A A0-GA2).
- Loosen two screws (4-104), and adjust inclination of the mirror base (4-101).
- Adjust the screw (4-59) properly so that the mirror base (4-101) is aligned in 45°.
- Repeat the above adjustments until the center of the collimator is in agreement with the center of the chart.
- When the adjustment is completed, lock the screws (4-104) and screw (4-59) with Pliobond.
- Operate the mirror two to three times, and make sure that the 45° alignment is satisfactory.

Fig. 30



#### 4. STOPPED-DOWN/FULL-APERTURE LIGHT METERING CHANGEOVER SWITCH ASSEMBLY

- Check contact piece (4-188 and 4-190) to insure that they are under the conditions shown below:

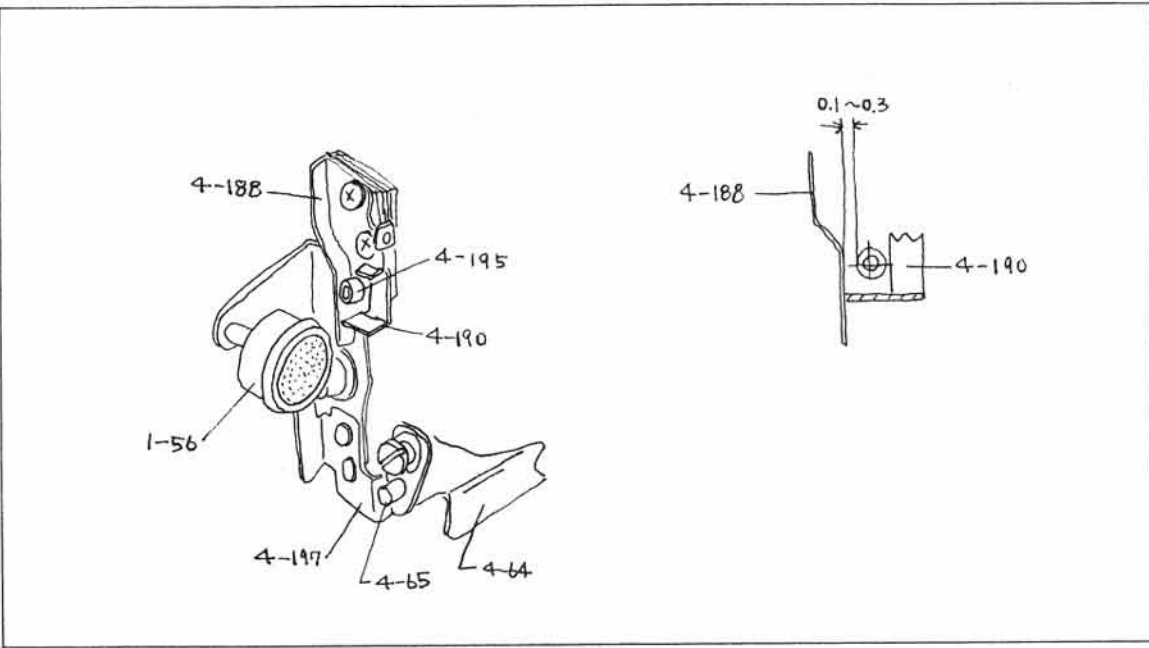
	Full-aperture metering *	Stopped-down aperture metering **
Contact piece (4-188) and (4-190)	Make	Break

\*Full aperture metering: With stop-down aperture button assembly (1-56) freed.

\*\*Stopped-down aperture metering: With stop-down aperture button assembly (1-56) pushed and locked.

- Adjust installed position or bend the contact piece (4-188) properly so that gap between the contact piece (4-188) and tube (4-195) is 0.1 to 0.3 mm when the stop-down aperture button assembly (1-56) is depressed causing the spring (4-197) to come into contact with connecting pin (4-65).  
(Use a dummy lens mount KL46E 100A 1006E00-GA25.)
- When the adjustment is completed, make sure that the contact piece (4-188) has a sufficient contact pressure against the contact piece (4-190).  
When adjustment is needed, properly bend the contact piece (4-188).

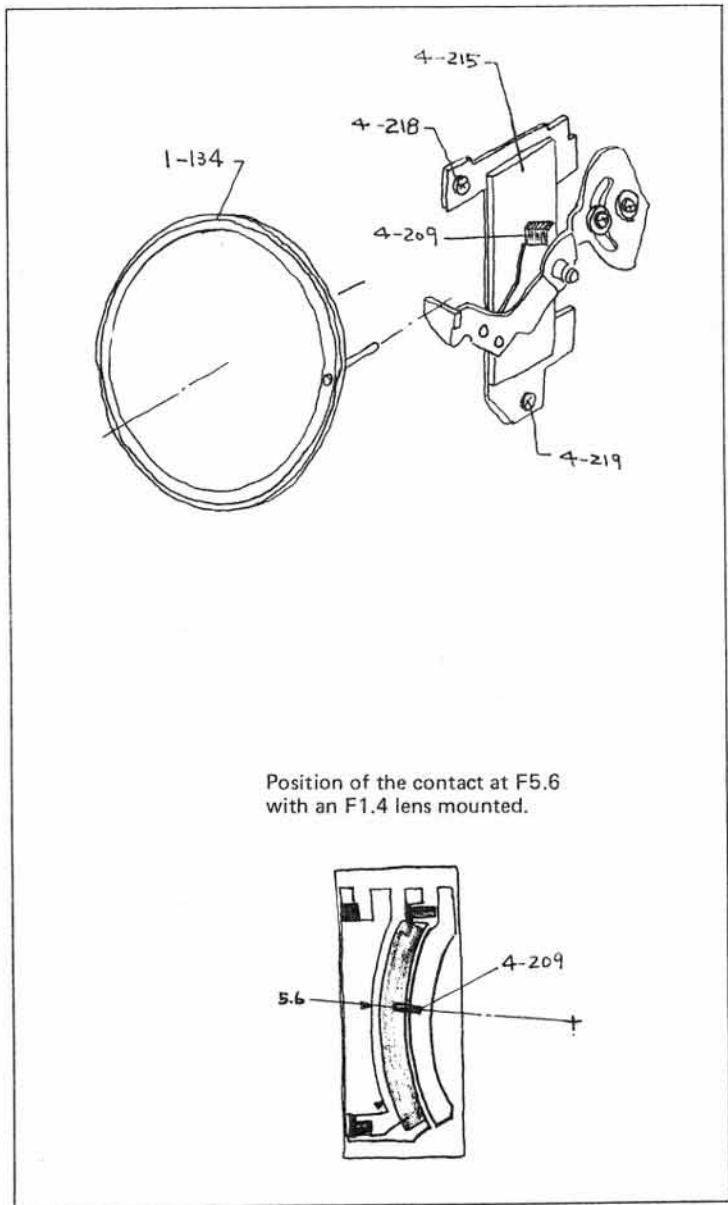
Fig. 31



**5. ADJUSTMENT OF CONTACT POSITION FOR F-VALUE APERTURE RESISTOR ASSEMBLY (4-215)**

- Check rotary plate assembly (4-205) to insure that it moves smoothly in response to movement of the aperture transmission ring assembly (1-134).
- With an F1.4 lens mounted on a dummy lens mount (100A 1006E00-GA25) used and the aperture set to F5.6, check the connector (4-209) to insure that it is coincided with the index.
- When adjustment is needed, move the aperture resistor assembly (4-215) after loosening screw (4-218 and 4-219).
- Move the connector (4-209) to the full-aperture side and stopped-down aperture side, and insure that no such an eccentricity that the movement causes it to come off the pattern exists.
- Make sure that the connector (4-209) is bent properly to the correct height, and that contact pressure is 16 to 20 grams.

**Fig. 32**





6. INSTALLATION OF LENS MOUNT ASSEMBLY (1-46) AND ADJUSTMENT OF FLANGEBACK

a. Installation

- Apply silicon grease to the coupling (1-67), and insert the coupling into the space between the self-timer and self-timer lever (1-66).
- Make sure that the plate (4-66) has been returned to the original position. When the plate has not returned to the original position, properly bend the lever (4-70).
- Depress the stop-down aperture button assembly (1-56), and make sure that the stopped-down/full-aperture light metering changeover switch turns on and off correctly.

b. Adjustment of flangeback

The rated flangeback (between the film plane and surface of the lens mount) is  $45.45 \pm 0.025$  mm.

- Select proper washer(s) (1-65)(55B95280), 167M23005 and/or 55B95390), and adjust flangeback to the above indicated rating.
- When flangeback is deviated from the rating without using any washer, properly file the surface of the lens mount which comes into contact with the camera body.
- When the surface of the lens mount is filed, check its parallelism against the camera body at four or more points.

Fig. 33

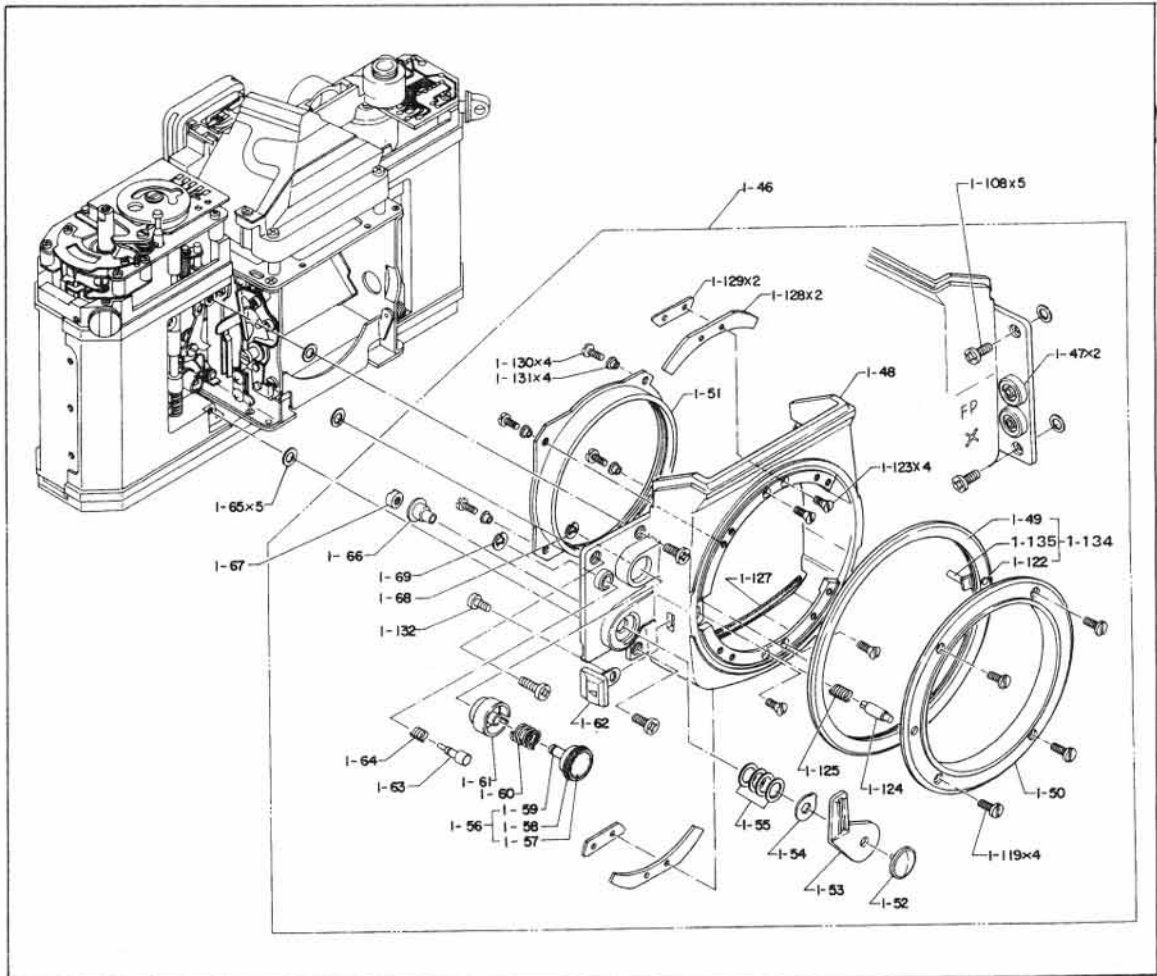
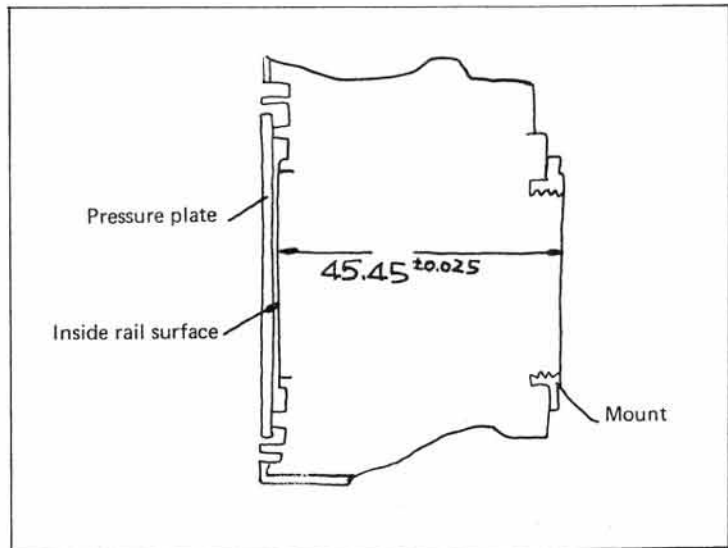


Fig. 34



## 7. LENS MOUNT ASSEMBLY (1-46)

### 7-1 Adjustment of gap on lens mount

Provide a gap between the ring (1-50) and mount (1-51).

The gap should be 5/100 to 15/100 mm.

#### a. Method to adjust and check

1. Use an F1.8 55 mm lens which stops at the correct position when mounted.
2. Screw the lens into the lens mount completely until it stops.
3. Set the aperture scale ring to "1.8", see if the section between "4" and "11" of the scale is faced to the immediately above direction.

#### b. Method of repairing

##### 1. Lens cannot be mounted tightly.

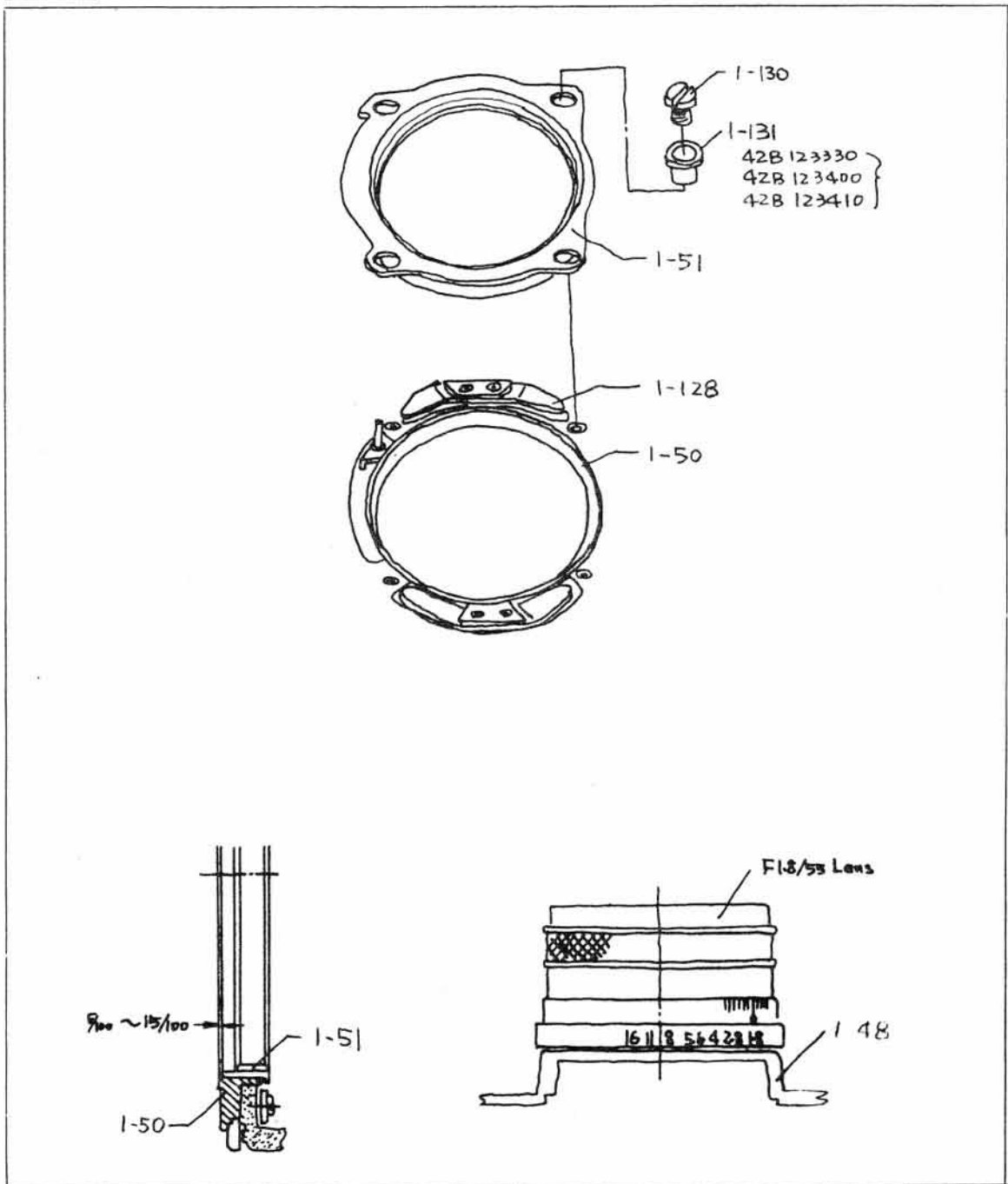
When the lens is loose, gap between the ring (1-50) and mount ring (1-51) is insufficient.

Use a longer bushing.

##### 2. Lens cannot be mounted lightly.

Clean the mount ring (1-51) and thread (42 mm dia.,  $P = \ell$ ), and slightly apply grease to the threads. When gap between the ring (1-50) and mount ring (1-51) is too deep, use a shorter bushing (1-131).

Fig. 35



7-2 Stop-down aperture button assembly (1-56)

Check this assembly to insure that the stop-down aperture button is locked when it is pushed and turned 30° (approx.) counterclockwise.

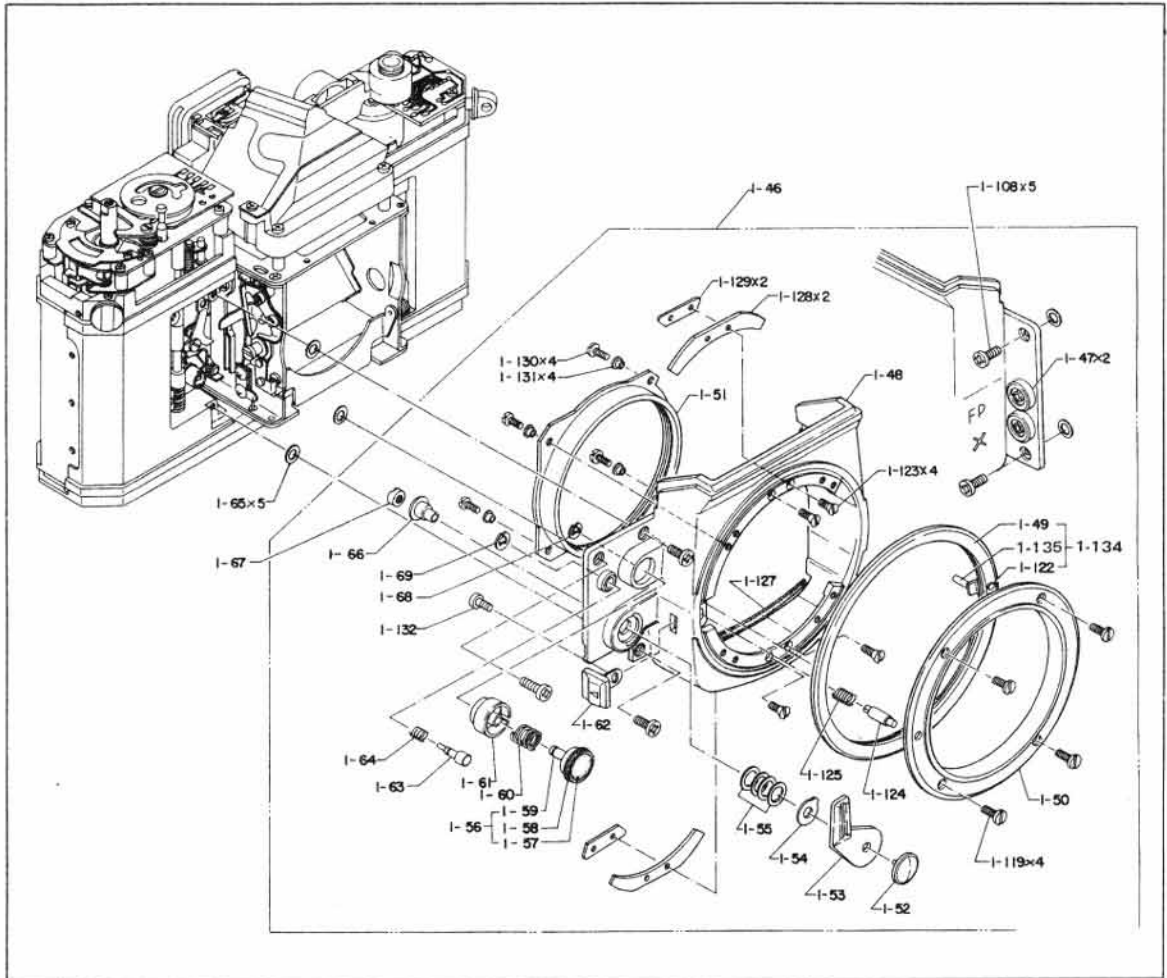
7-3 Shutter speed dial assembly (1-120)

- a. Check this assembly if it moves smoothly without any dragging.
- b. Check the shutter speed dial assembly (1-120) to insure that it is caused by the spring to return to the stopping down direction.

7-4 Pin (1-124)

- a. Check the pin to insure that its projection from the ring (1-50) is  $0.7 \pm \frac{0}{0.2}$  mm.
- b. Check this pin to insure that it operates smoothly and clicks when a lens is mounted.

Fig. 36



## 8. VIEWFINDER

### a. Adjusting viewfinder focusing

- Mount a lens having correct flangeback on the camera, set the focusing ring of the lens to  $\infty$  (Infinity), and adjust split images so that they are in agreement.
- When adjusting three nuts (3-17), be sure to loosen them in same number of turns.
- When this adjustment is completed, be sure to lock the nuts with Pliobond.

NOTE: Do not look at an object through a window glass because flatness of the window glass may not be correct.

- When adjusting viewfinder focusing by the use of an auto-collimator, limit focusing position within  $\pm 0.02$  mm.

### b. Vignetting in field of view

When a remarkable vignetting exists in the field of view, replace the prism (3-6) with a new one.

### c. Cross-view (Direction of a directly seen object is deviated from that of field of view observed through the viewfinder)

- Make sure that cross-view is within 10 cm at 5 meters.
- Check the lens (2-46) for its position, and when the lens position is normal, replace the prism (3-6) with a new one.

### d. Image tilting

When an image in field of view of the viewfinder is tilted more than  $1^{\circ}30'$ , replace the prism with a new one.

### e. Differences with Fujica ST701

- Mirror: The external dimensions are same. Silver coating has been changed to aluminum coating.
- Focusing screen: The external dimensions are same. The performance differs because no condenser lens is used. The focusing screen for Fujica ST605 can be discriminated from that for Fujica ST701 by the projection shown in Fig. 38.
- Penta prism: There are two types; one of them has the same external dimensions, and the other is smaller. The coating has been changed from silver to aluminum.

NOTE: The above parts are used commonly with Fujica ST601.

Fig. 37

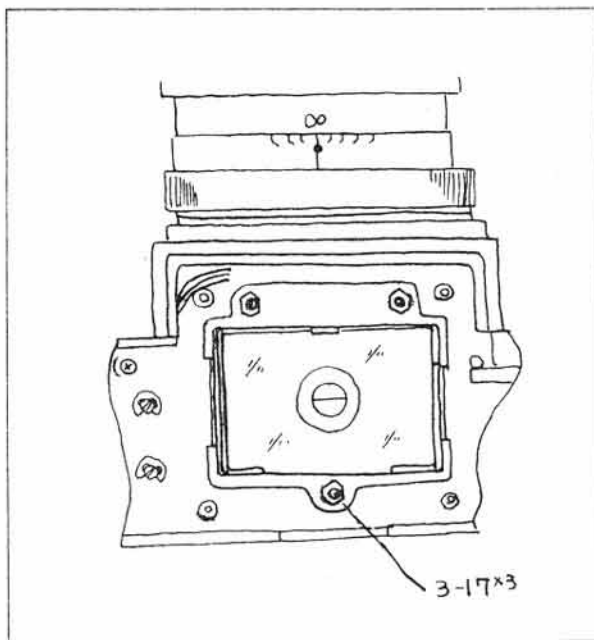
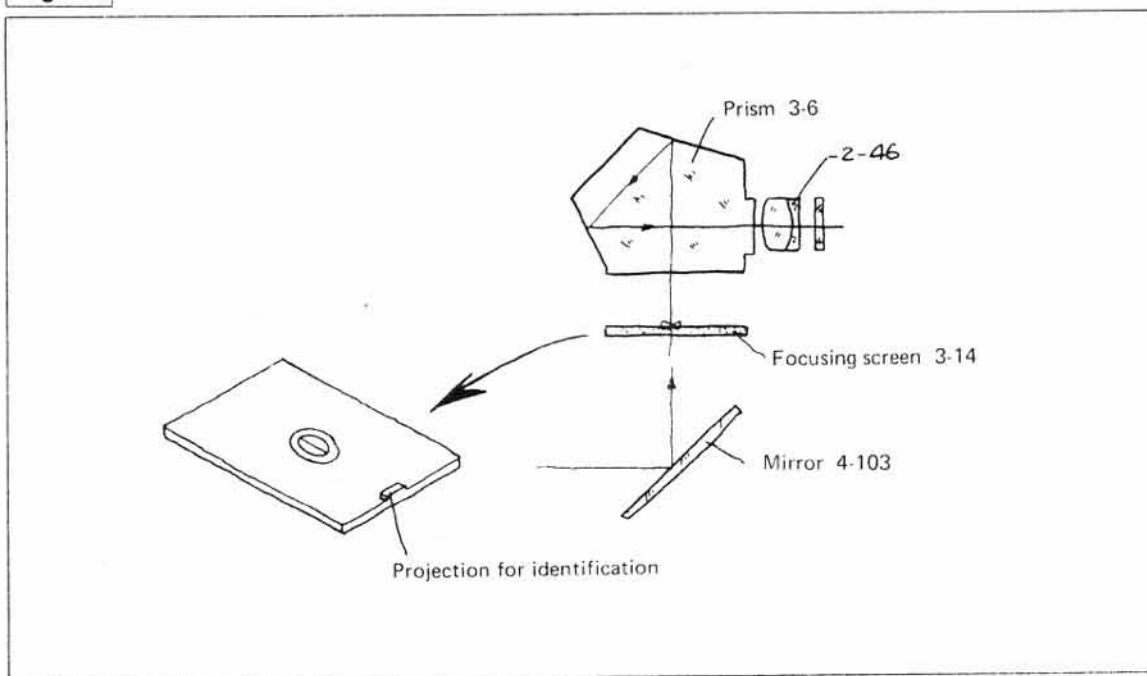


Fig. 38



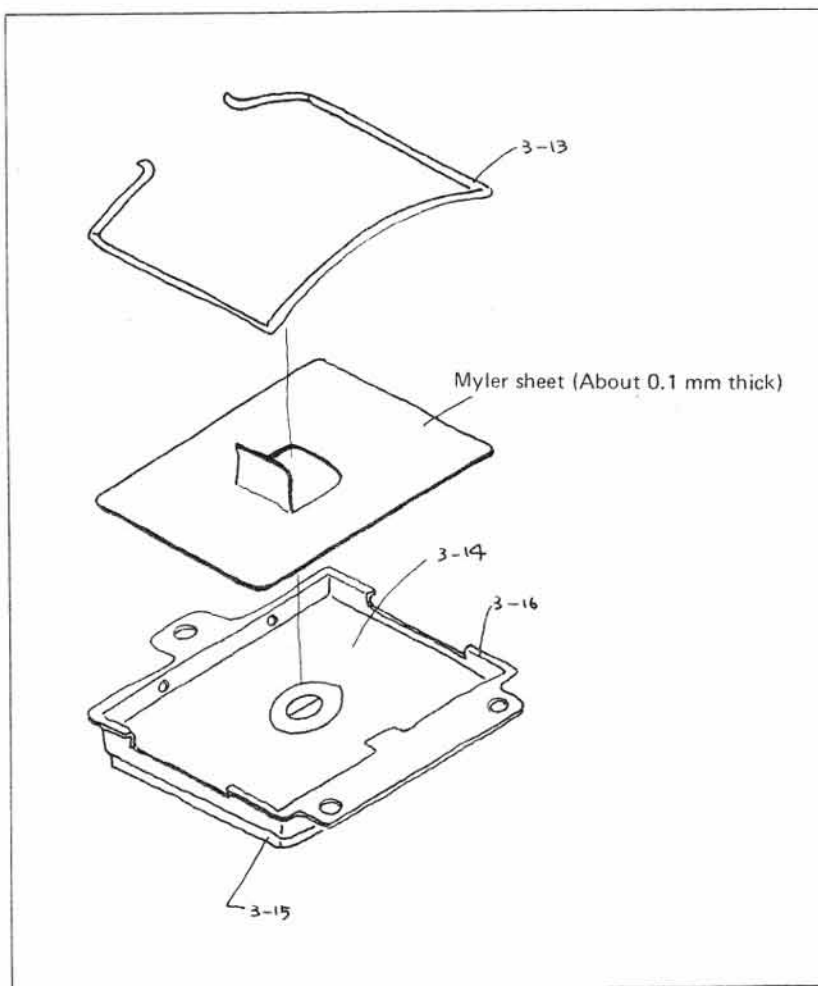


f. Methods to disassemble and reassemble focusing glass (3-14)

When the focusing glass (3-14) is disassembled or reassembled incorrectly, it may be scarred with the holder (3-13). Recommend the methods described below be regarded.

- 1) Place the Myler sheet (0.1 mm thick) which is placed in the case (3-16) on the focusing glass (3-14). (An ordinary paper is too soft.)
- 2) Reform the holder (3-13) so that all four corners are securely held, and install it.
- 3) Push four corners of the cover (3-15), and make sure that the folder (3-13) securely holds down the focusing glass (3-14).
- 4) Hold the tab of the Myler sheet with your fingers, and remove the focusing glass (3-14) together with the Myler sheet and holder (3-13).

Fig. 39



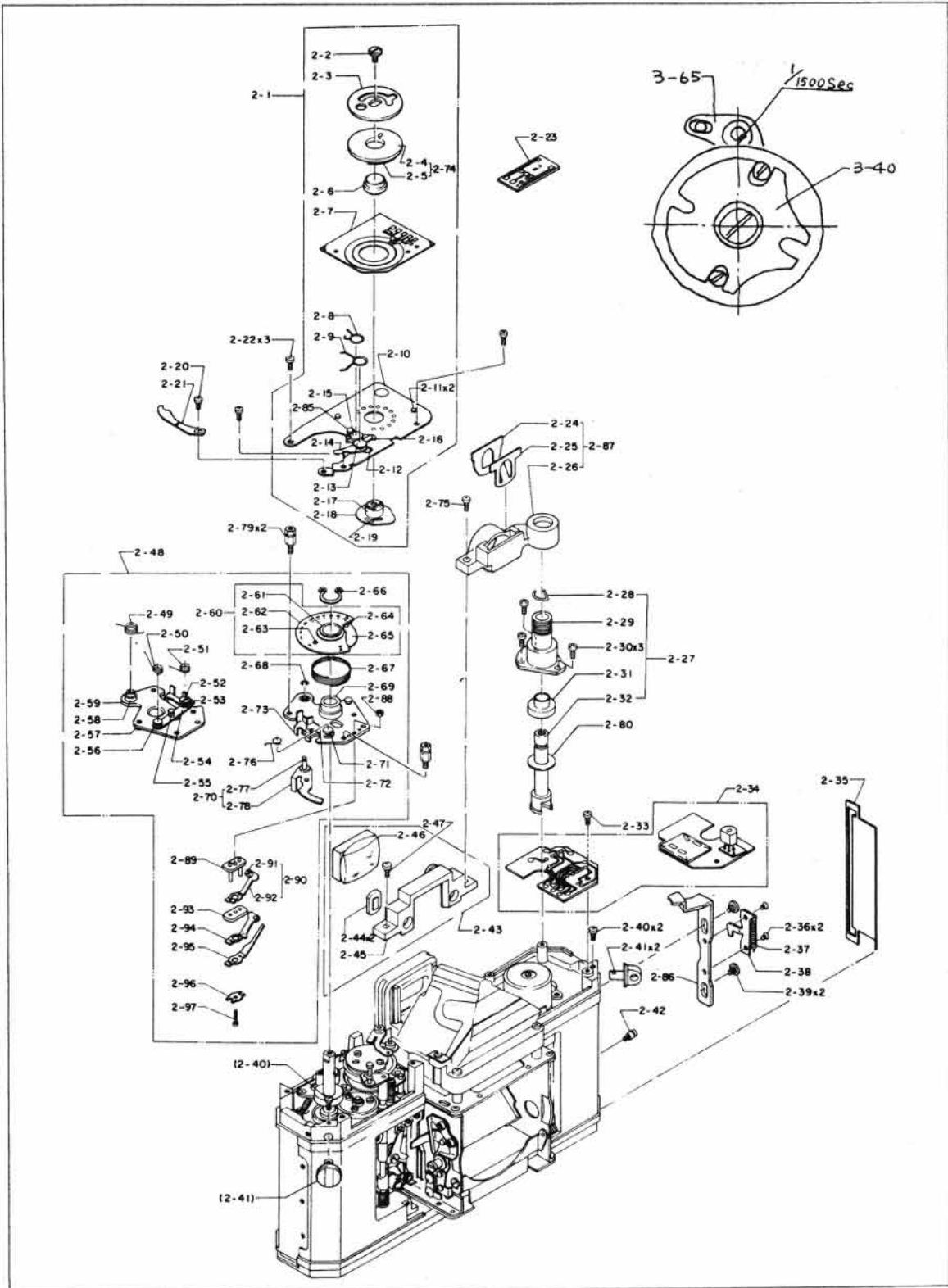
## 9. INSTALLATION OF EXPOSURE COUNTER AND ADJUSTMENT OF ADVANCEMENT

- Apply Helicolube/Molykote mixed grease to the eccentric cam (3-98).
- Check the zero return lever assembly (2-78) and pin (2-55) for their positions, install the counter dial assembly (2-48), and tighten it with two screws (2-79).
- Wind up the film advance lever, and make sure that the exposure counter advances one exposure by one exposure correctly.  
When the condition is abnormal, properly bend the feed claw (2-73) and stop claw (2-72).
- Make sure that the exposure counter resets to "S" (zero-reset) when the back cover is opened.  
When the condition is abnormal, properly bend the zero return lever (2-78).  
When the spring (2-67) is jammed, replace it with a new one.

## 10. INSTALLATION OF SHUTTER RESISTOR ASSEMBLY (2-1)

- Set the shutter mechanism to the position for 1/1500 sec. shutter speed.
- Set the click plate portion of the shutter resistor assembly (2-1) to the position for 1/1500 sec. shutter speed.
- Position the coupling (3-40) as shown in Fig. 40.
- Insert the guide pin (2-12) into the opening on the connecting plate (3-93), and install the shutter resistor assembly (2-1).
- Make sure that the pin (2-19) enters the coupling (3-40) correctly and that the click plate portion of the shutter resistor assembly turns smoothly toward the range from "B" to 1/1500 sec.
- When the click plate does not click correctly, check the coupling (4-40) for defective grooves.  
When adjustment is needed, properly bend the leaf spring (2-18).

Fig. 40



## 11. ADJUSTMENT OF MAIN SWITCH FOR EXPOSURE METER CIRCUIT

Make sure that the switch turns on when the shaft (3-94) is pushed down 0.4 to 0.7 mm. When adjustment is needed, properly bend the switch contact assembly (2-90 and 2-94).

## 12. ADJUSTMENT OF FILM ADVANCEMENT LOCK AND LOCK RELEASE MECHANISM

Make sure that the film advance lever cannot be wound with the shutter release button depressed. Make sure that the shutter release button cannot be depressed with the film advance lever wound in a half way.

- Depress the release shaft (3-92), and see if the end of the lever (2-14) enters the notch of the claw ring (1-107), causing the film advance lever not to be wound.  
Further, make sure that the film advance lever can be wound when the release shaft is returned.
- Make sure that the end of the lever (2-16) enters the notch of the release shaft (3-92) with the film advance lever wound in a half way, causing the release shaft not to be depressed. Further, make sure that the release shaft can be depressed when the film advance lever is returned.
- Properly bend the connecting plate (3-93) and adjust direction of the shaft (3-94) so that the two operations described above are satisfied.
- Turn the shutter dial with the shutter release button depressed, and see if the shutter dial can be turned 360°.  
When the shutter speed is adjusted and the shutter dial drags, the slope of the cam (3-48) is defective. Carefully correct the slope with a file so as not to damage the step for 1/60 sec. shutter speed.

Fig. 41

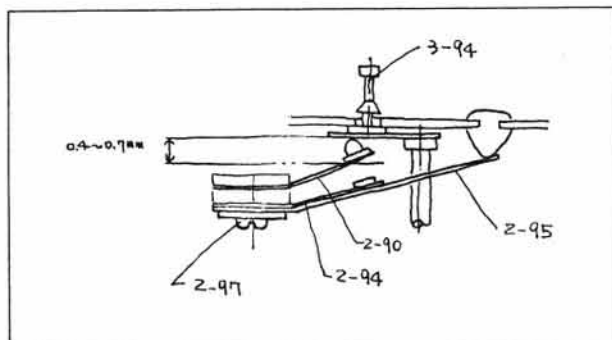
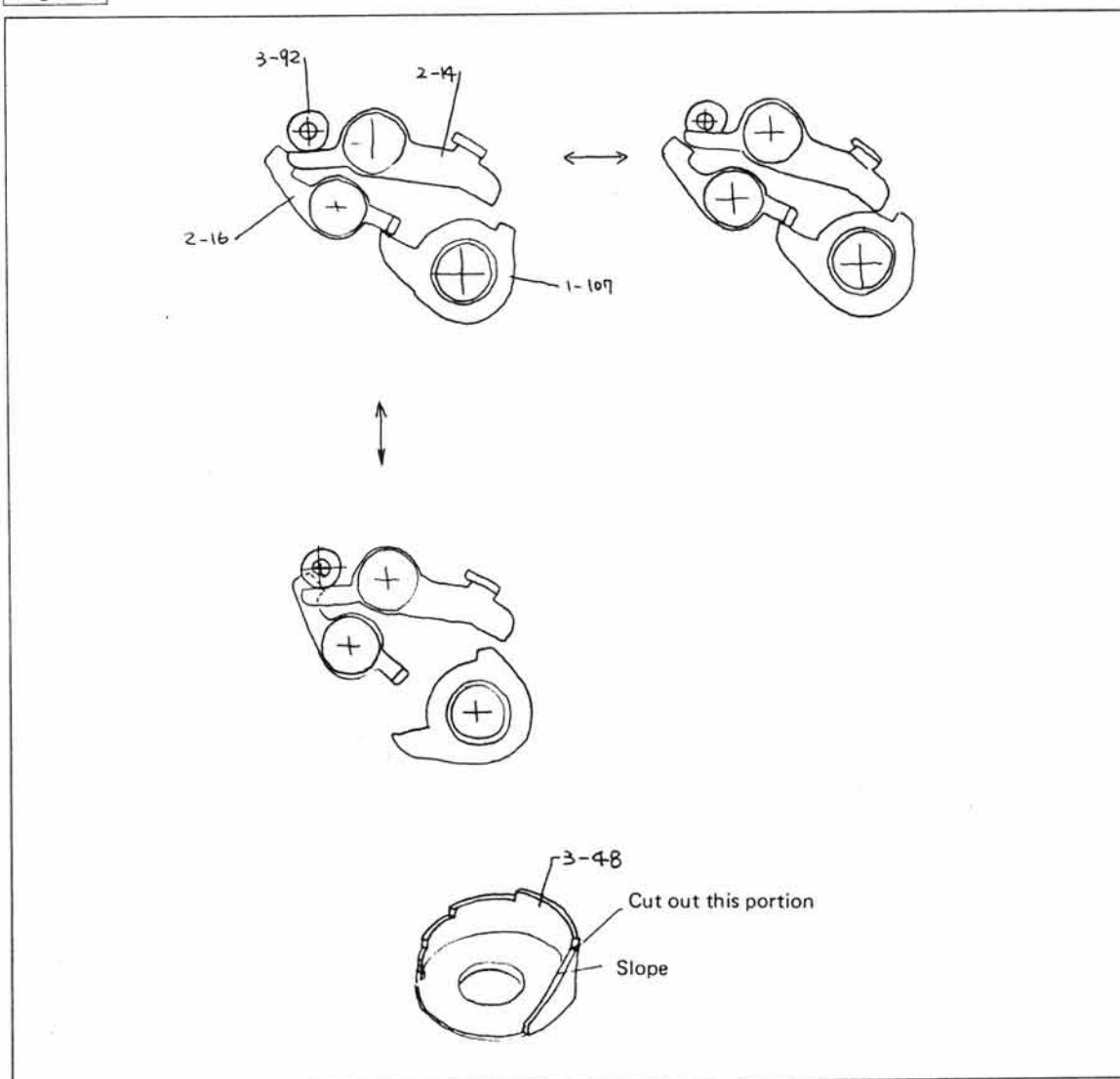


Fig. 42



### 13. INSTALLATION OF AMPLIFIER AND WIRING

- Install the amplifier (2-34) with the screw (2-33).
- Connect each lead wire as shown in Fig. 43. When soldering the lead wires, do not use paste or flux.

Fig. 43

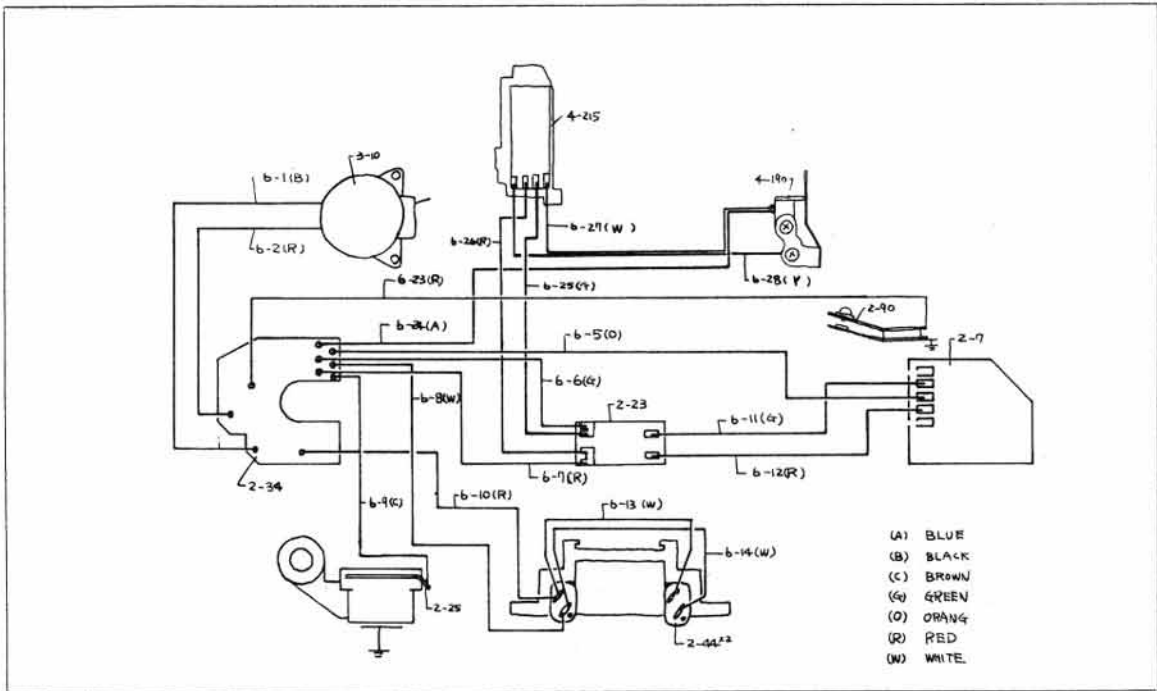
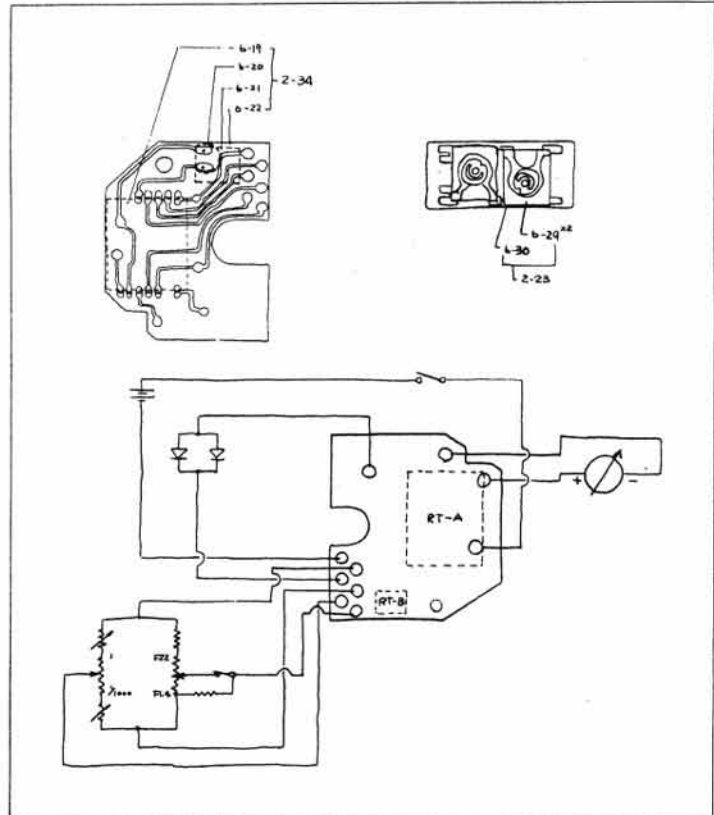


Fig. 44





#### 14. ADJUSTMENT OF EXPOSURE METER

- Adjustment of LV11 (Full-aperture metering)

Use an F1.8/55 mm lens.

Adjust two 1.5 k $\Omega$  variable resistors (6-29) properly so that the meter needle is in the center of the index. Next, adjust voltage across terminals "a" and "b" to 266 mV ( = 19 mV  $\times$  14 stops). The permitted adjustment range of the 1.5 k $\Omega$  resistor is  $\pm$  3 EV.

- Adjustment and confirmation of LV8 and LV14

Adjust the exposure meter at these light values so that the values shown in the following table are satisfied.

	LV8	LV11	LV14
Light source	96 rlx	768 rlx	6144 rlx
Aperture	f5.6	f5.6	f5.6
Shutter speed	1/8 sec.	1/60 sec.	1/500 sec.
Film speed	100	100	100

- Position of ASA100

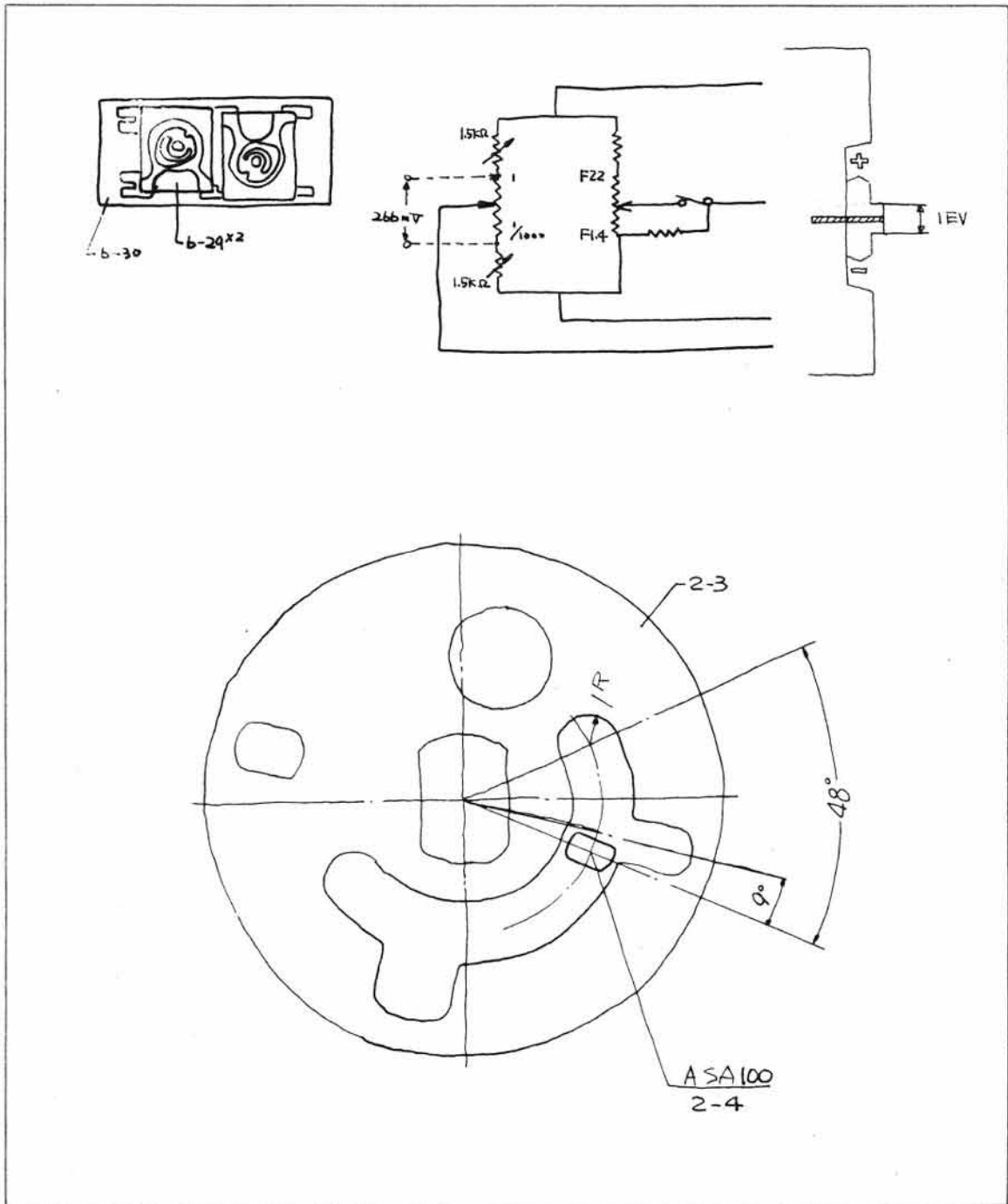
This position can be selected by using a special tool. Fig. 45 shows the position.

- Confirmation of stopped-down aperture metering

Make sure that accuracy of stopped-down aperture metering is within  $\pm$  1 EV under the conditions shown in the above table.

When repairing is needed, adjust position of the F-value selector or replace it with a new one.

Fig. 45



## 15. CHECKING EXPOSURE METER

### a. Power supply

Voltage of the mercury battery should be  $1.5 \pm 0.1$  V per one when an  $820\Omega$  load is applied to NZ-13.

### b. Switch circuit

When the switch is turned on, voltage across the positive (+) and negative (-) terminals of the power supply (amplifier terminal) should be approximately 3V.

### c. Amplifier

Check the amplifier to insure that voltage at each terminal of the amplifier is as shown in Fig. 46. When abnormal, check each part for faulty soldering.

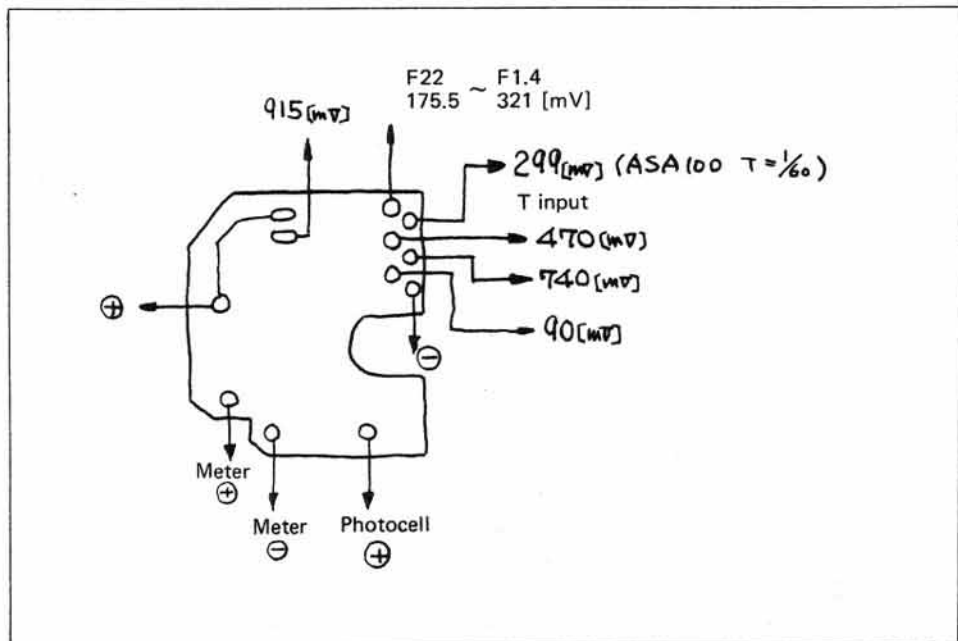
When each part is soldered correctly and still abnormal, the amplifier is defective.

### d. Meter

Measure internal resistance of the meter by the use of a tester.

When the tester indicates a constant resistance as soon as the meter needle deflects, the meter has no broken wire. The rated internal meter resistance is  $1.4 \pm 0.1$  k $\Omega$ .

Fig. 46



e. Silicon photocell

Finish soldering or unsoldering of the lead wire for the photocell quickly.  
Disconnect the lead wire, and check each photocell for existence of continuity by the use of a tester.

f. Shutter resistor assembly

Check the contact plate (2-5) to see if it is placed on the printed circuit board (2-7) correctly.  
The rated contact pressure is 10 to 20 grams.  
Make sure that resistance varies in response to dial turning, and make sure that resistance of each resistor is correct as shown in Fig. 47.

g. Transit board assembly

Make sure that resistance of the variable resistor (6-29) is 1.5 k $\Omega$ .

h. F-value selector

Make sure that the connector (4-209) is correctly placed on the F-value selector (4-217).  
(Contact pressure: 10 to 20 grams)  
Make sure that resistance varies in accordance with movement of the F-value selector (4-217).  
Make sure that resistance is within that shown in Fig. 49.

Fig. 47

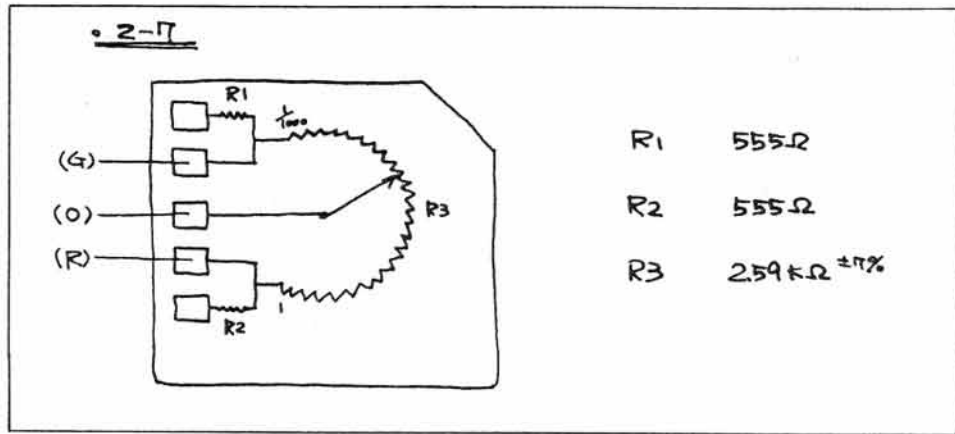


Fig. 48

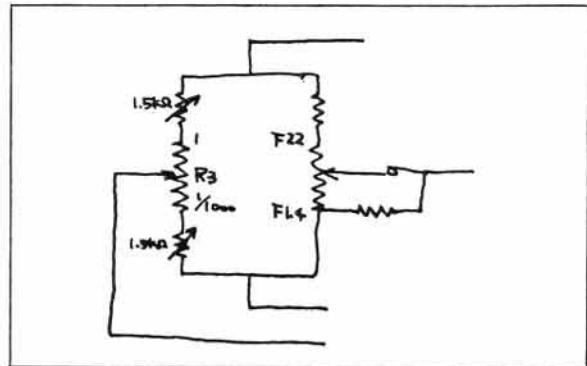
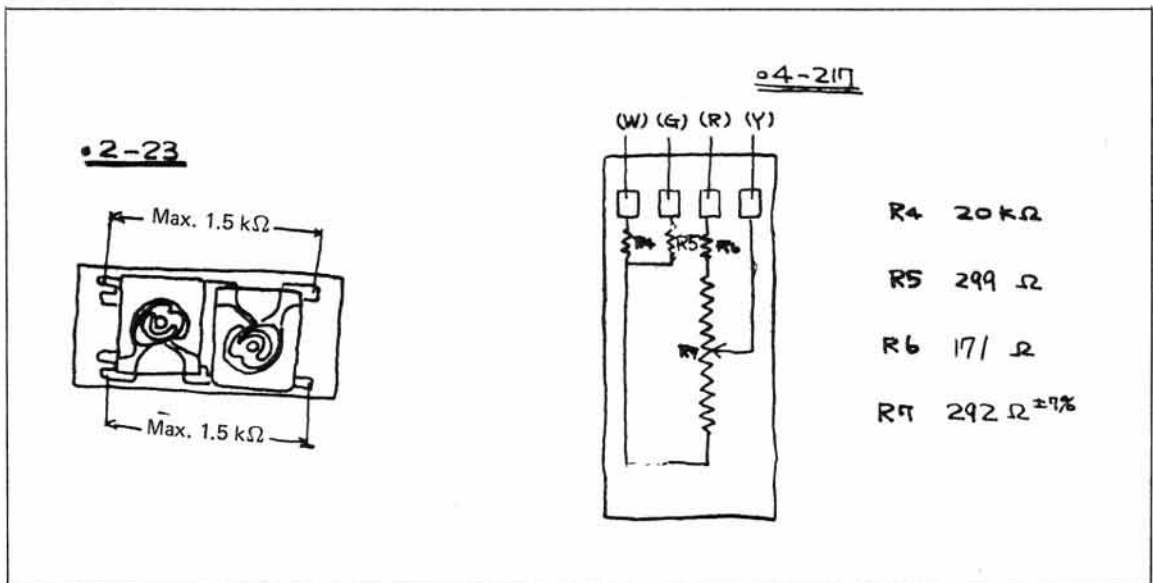


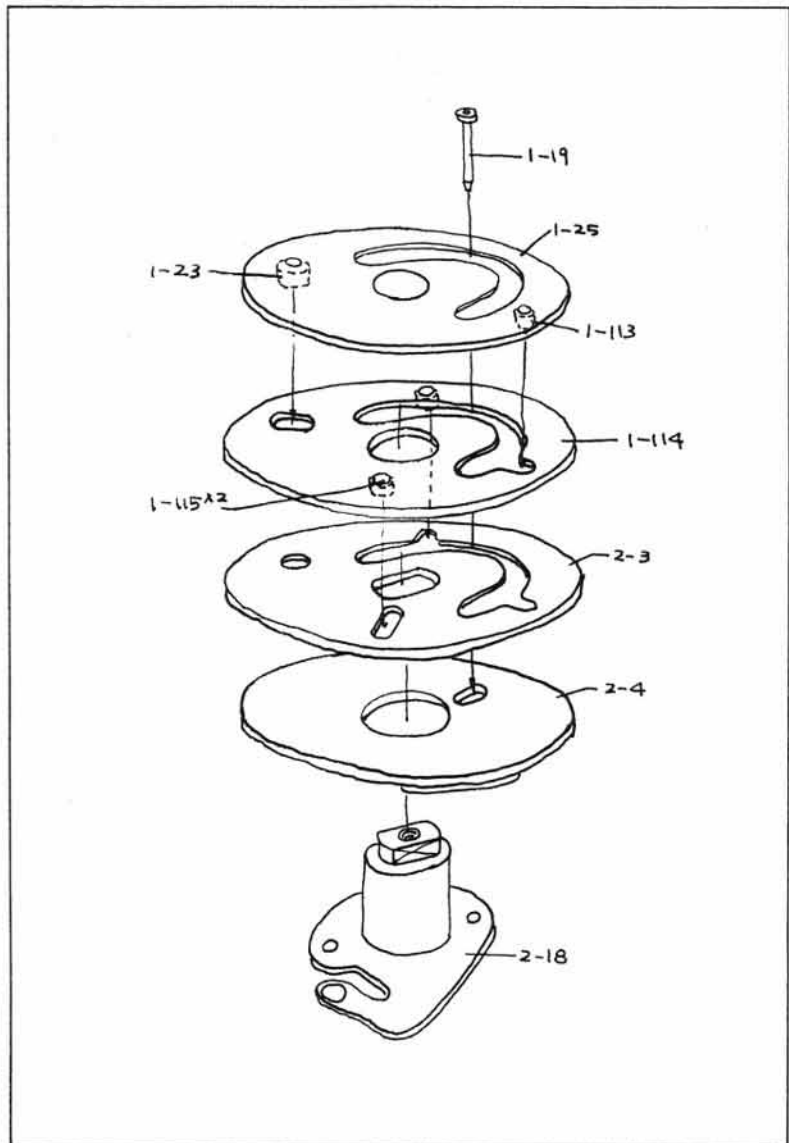
Fig. 49



## 16. INSTALLING TOP COVER ASSEMBLY (1-1)

- Set the shutter speed selector dial of the top cover assembly to "B" and film speed to ASA 25.
- Set the appropriate mechanism in the camera body side to "B" and ASA 25, and combine the connecting plate assembly (1-29).
- Carefully install the top cover after connecting (soldering) the lead wire to be extended to the accessory shoe so that the lead wire is held between the top cover and camera body.
- Turn the shutter speed selector dial and insure that it turns 360° smoothly and clicks correctly.

Fig. 50

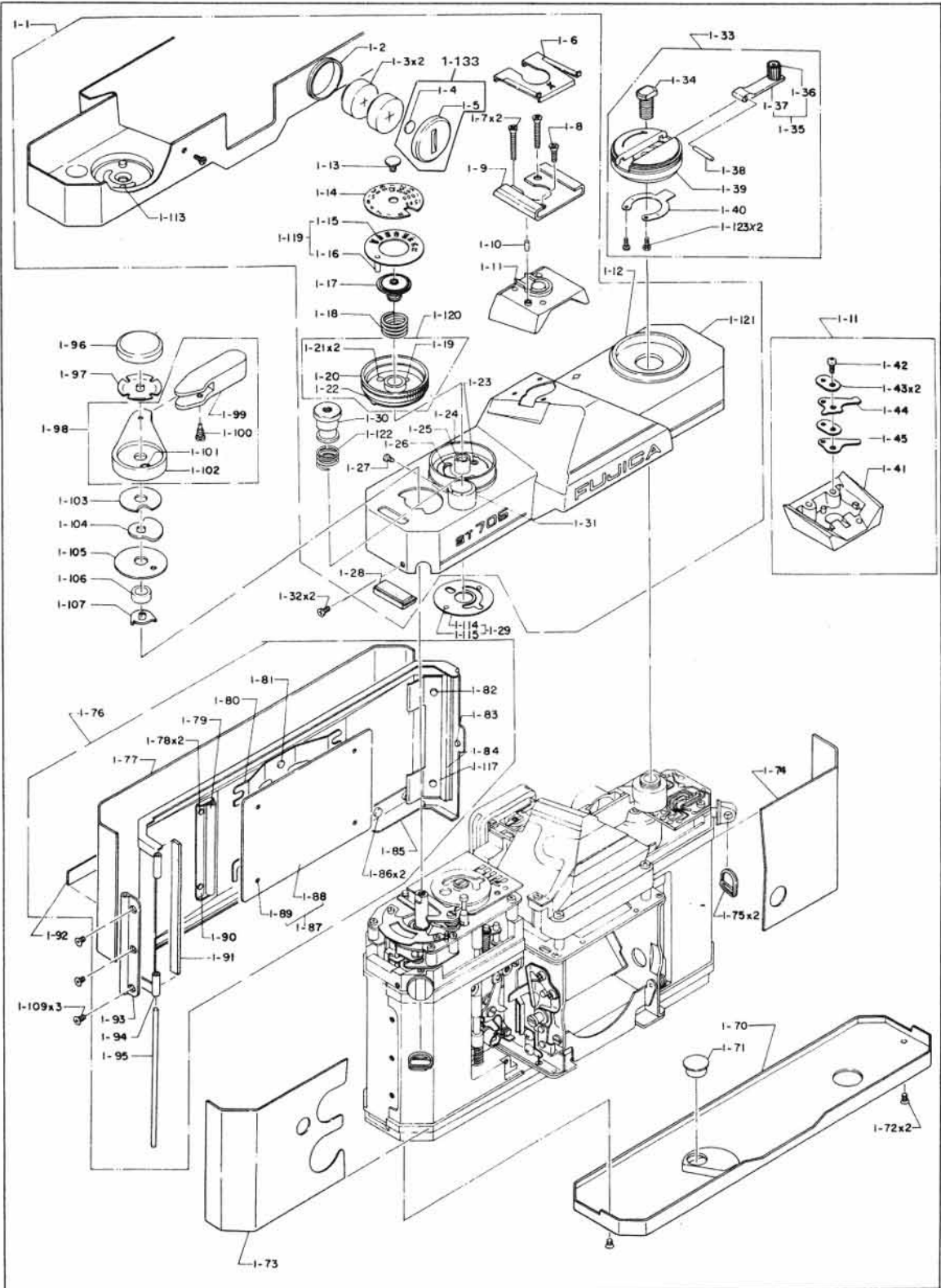




**17. INSTALLING FILM ADVANCE LEVER ASSEMBLY (1-98), FILM REWIND KNOB ASSEMBLY (1-33) AND REWIND BUTTON (1-71)**

- Assemble the plate (1-107), collar (1-106), plate (1-105), plate (1-104), washer (1-103) and film advance lever assembly (1-98) in that order, and secure them with the screw (1-96). Make sure that the knob (1-99) can be folded with a proper friction. Make sure that the film advance lever returns with a proper friction from a middle of the winding up stroke.
- Install the rewind knob assembly (1-33) by paying attention on the leaf spring (1-40). Make sure that the leaf spring operates normally providing a click.
- Apply the rewind button (1-71) to the bottom cover, and install the bottom cover. Depress the button, and make sure that the lock effects and the sprocket idles. Wind up the film advance lever, and make sure that the lock is unlocked and that the sprocket does not turn reversely.

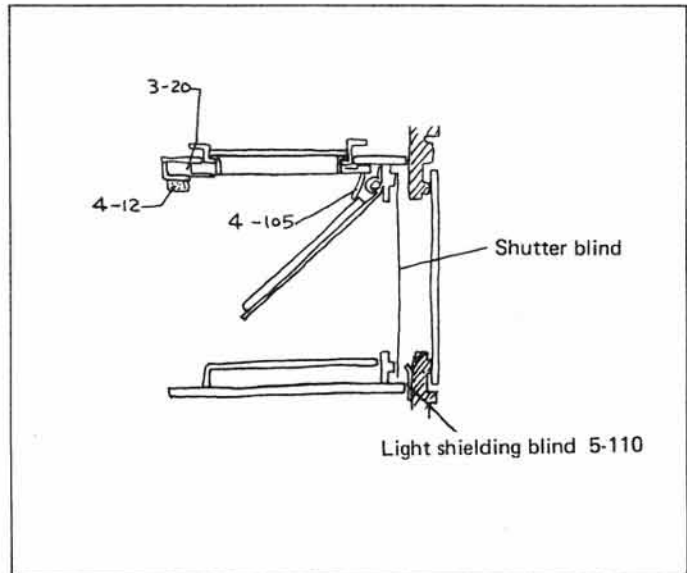
Fig. 51



## 18. LIGHT SHIELDING PARTS

Make sure that all light shielding parts have been installed correctly and securely in their positions.

Fig. 52



IV.  
**INSPECTION**

## IV. INSPECTION

INSPECTION	METHOD OF INSPECTION	REMARKS
<p>1. EXPOSURE METER</p>	<p>Load a battery having the rated voltage, mount a lens (F1.8/55 mm lens is desirable), and inspect.</p> <p>(1) Set film speed selector to ASA100, shutter speed selector to 1/60 sec., make the stop-down aperture button free, depress the shutter release button in a half way, face the lens of the camera to a bright object, and make sure that the meter needle moves.</p> <p>(2) Face the lens of the camera to an object having a proper brightness so that the meter needle is in the center of the meter, change over shutter speed and aperture, and make sure that the meter needle moves accordingly.</p> <p>(3) Return the shutter release button, and make sure that the meter needle does not move.</p> <p>(4) Lock the stop-down aperture button, and repeat the above inspection.</p> <p>(5) Set the meter needle to the center position, stop down the aperture, and make sure that the meter needle is separated from the bottom line of the proper exposure zone.</p> <p>(6) When the meter switch is turned on with the camera lens faced to a dark object, the meter needle may lower below the zero position.</p>	
<p>2. OPERATIONS OF THE PARTS FOR MAIN BODY</p> <p>2-1 Film advance lever</p>	<p>(1) Check that the film advance lever cannot be turned with the shutter release button depressed.</p> <p>(2) Check that the shutter release button can be locked in a middle of turning stroke of the film advance lever.</p> <p>(3) Check that the film advance lever returns with a proper friction from a middle of the turning stroke.</p>	
<p>2-2 Shutter release button</p>	<p>(1) Check that the shutter is correctly released when the film advance lever is turned and the shutter release button is depressed and that the shutter release button returns smoothly.</p>	

INSPECTION	METHOD OF INSPECTION	REMARKS
2-3 Self-timer	<p>(2) Check that the shutter release button is securely locked when the green and red dots are matched.</p> <p>(3) Check that the power is turned on when the shutter release button is depressed in a half way.</p> <p>(1) Turn the film advance lever, fully set the self-timer, depress the self-timer start button, and check that the self-timer operates, the shutter is released and that the shutter release button returns correctly.</p>	
2-4 Film rewind button	Depress the film rewind button and see if the sprocket is freed. Turn the film advance lever and see if the film rewind button correctly resets and if the sprocket operates.	
2-5 Film advancing system	Load a test film, repeatedly turn the film advance lever ten times, and check that the film is advanced correctly, the film advance lever returns correctly and that the film can be rewound correctly. Check the back cover to see if the back cover can be opened, closed and locked correctly with the film loaded.	
3. SHUTTER		
3-1 Operation of shutter speed selector dial	<p>(1) Check that the shutter speed selector dial cannot be shifted to other shutter speed from "B" when the shutter release button is depressed.</p> <p>(2) Turn the shutter speed selector dial from "B" to 1/1500 sec., and see if it turns smoothly and clicks at each shutter speed.</p>	
3-2 ASA shifting operation	Shift ASA number from "25" to "3200" and from "3200" to "25", and see if ASA numbers can be shifted smoothly.	
3-3 Operation of shutter	<p>Mount a lens, set the focusing ring to the minimum, set the aperture selector ring to full open position, open the back cover, turn the film advance lever, release the shutter, and see if the shutter operates correctly.</p> <p>Repeat this test three to four times at shutter speeds 1/1500, 1/60, 1/1 and B.</p>	
4. EXPOSURE COUNTER		
4-1 Advancing	<p>Close the back cover, turn the film advance lever and see if the exposure counter is advanced correctly.</p> <p>Check that ten frames (exposures) are advanced correctly from 8 to 1 one by one.</p>	

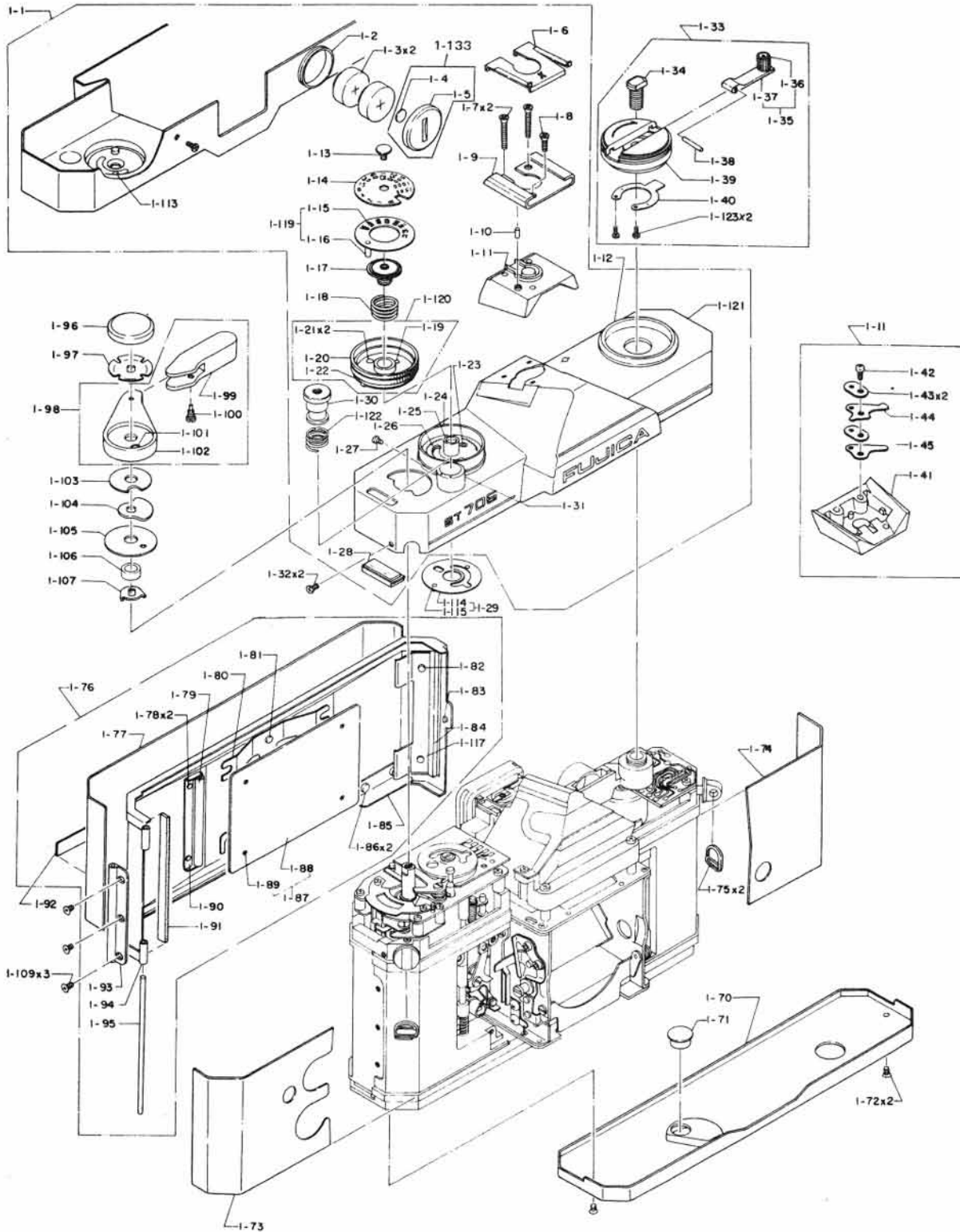
INSPECTION	METHOD OF INSPECTION	REMARKS
4-2 Zero reset	When the film is advanced ten frames (upto 8), open the back cover, and check the dial to see if it returns to S correctly.	
5. VIEWFINDER		
5-1 Coincidence of inf	Mount a lens, set the distance scale to "inf", observe an objective in a remote place, see if the split images are matched. A slight overage is permitted but shortage should not exist.	
5-2 Cross-view	Mount a lens on the camera, and check that no cross-view exists. Cross-view should be limited to 10 cm or less at approximately 5 meters.	
5-3 Vignetting in field of view	Check that vignetting in field of view, intrusion of a part into the field of view or deformation of frame in field of view does not exist.	
5-4 Dust, scar or contamination	Check that dust, scar or contamination which hinders field of view does not exist.	
5-5 Indication of shutter speed	A shutter speed indicated in the viewfinder should be agreed with that on the shutter speed selector dial. Noticeably tilted characters are not permitted.	
6. LENS BARREL		
6-1 Manual stop-down operation	Check stop-down operation at "inf" and minimum distance. Depress the aperture selector button, fully open the aperture, stop down the aperture to the minimum, fully open the aperture again, and check that aperture changes correctly and that the click effects. Any of six blades of the diaphragm should not remain in the former aperture position.	
6-2 Automatic stop-down operation	Set the aperture selector ring to the minimum at "inf" and minimum distance, operate the shutter, and check that the aperture is stopped down to the minimum correctly.	
6-3 Delay in stop-down	Set the focusing ring to the minimum distance, set the aperture selector ring to the minimum, set shutter speed to 1/1500 sec., open the back cover, operate the shutter, and check that the diaphragm and shutter blind are synchronized timely.	
6-4 Operation of helicoid	Turn the focusing ring from "inf" to the minimum distance and from the minimum distance to the "inf", and check that the helicoid operates smoothly and equally toward the total stroke without catching or slackness.	



INSPECTION	METHOD OF INSPECTION	REMARKS
6-5 Installation of lens barrel	Install and remove a lens barrel three times, and check that the lock pin assembly (2-107) operates correctly and that the lens can be mounted on the camera lightly and smoothly.	
7. APPEARANCE	<ol style="list-style-type: none"> <li>(1) Scar, scratch, peeled off coating, lack of balsam, discolored lens coating, or thumb print should exist on the lens.</li> <li>(2) Scratch, damaging, gap between fitted parts or others which harm the appearance should not exist on the exterior of the camera.</li> <li>(3) All parts should have been installed securely and correctly.</li> <li>(4) All parts which have been installed with adhesive should not peeled off or floated, and adhesive should have not come out from such parts.</li> <li>(5) All engraved marks, symbols or characters which are to be filled with paint of appropriate color should be properly and correctly filled with the paint of the specified color.</li> </ol>	
8. SETTING OF PARTS AFTER COMPLETING THE INSPECTION	<ol style="list-style-type: none"> <li>(1) Focusing ring: inf</li> <li>(2) Shutter: To be released</li> <li>(3) Shutter speed selector dial: ASA100; 1/1500 sec.</li> <li>(4) Battery: Unload</li> <li>(5) Exposure counter: S</li> <li>(6) Self-timer: To be released</li> <li>(7) Aperture selector button: Free</li> <li>(8) Shutter release button: Free</li> </ol>	

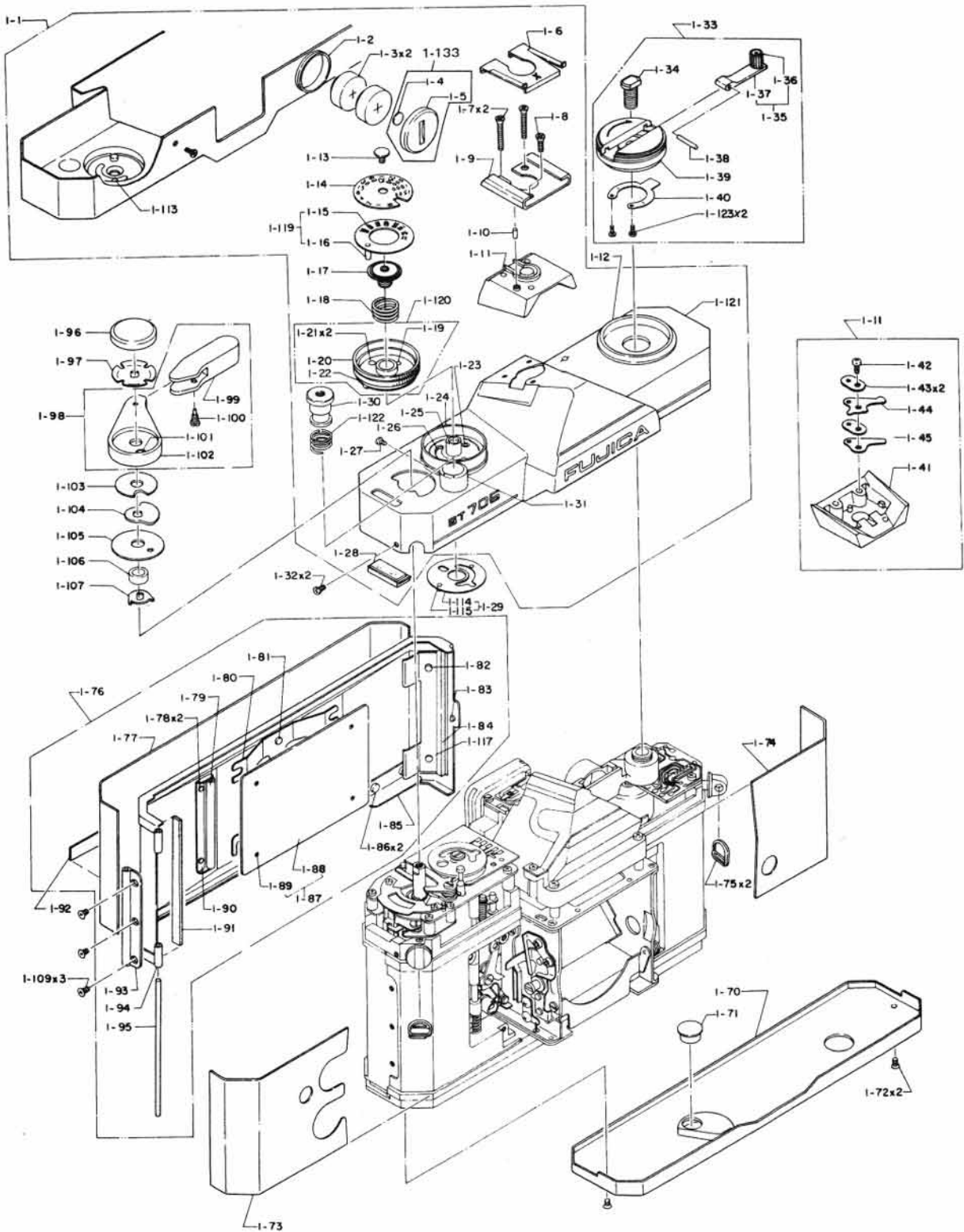
V.  
**PARTS LIST**

Fig. 1-1



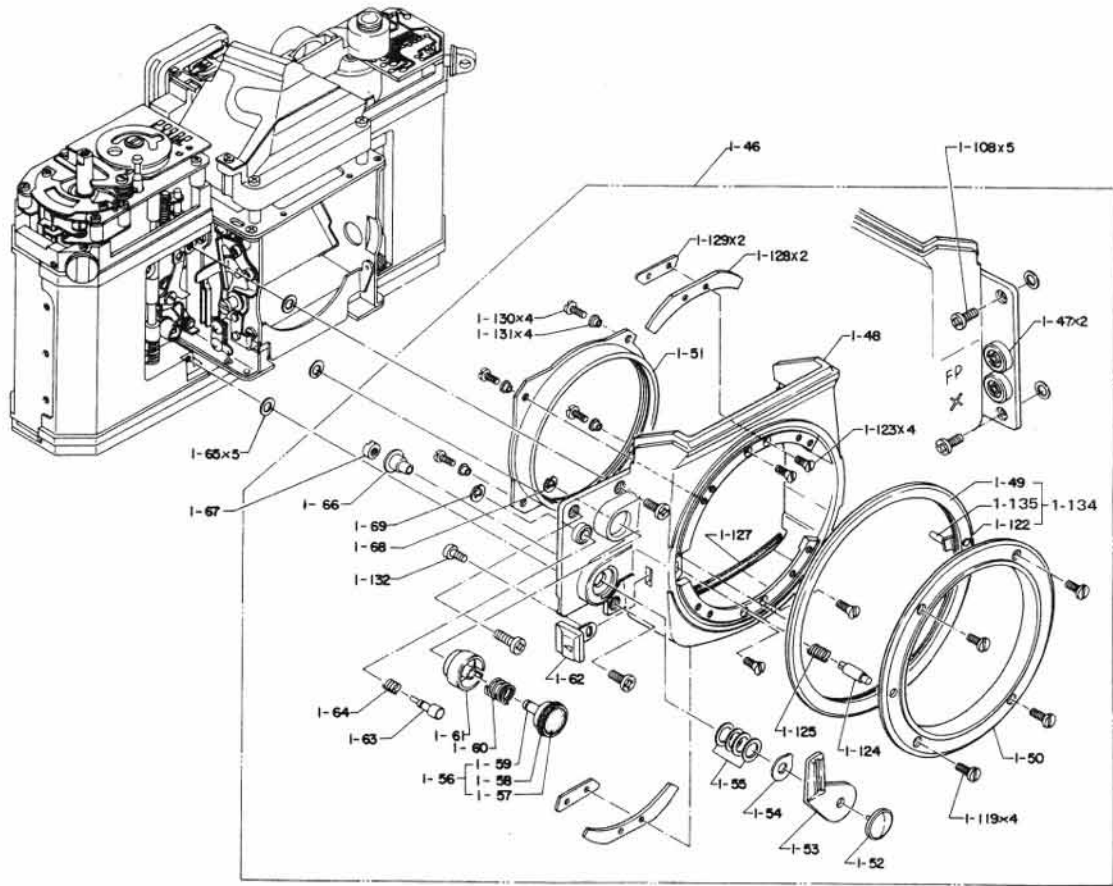
REF. NO.	PART NO.	PART NAME	Q'TY	COMMONLY USED WITH			REMARKS
				ST701	ST801	ST605	
1- 1	303A1443100	Top cover assembly	1				
1- 3	104K195780	Battery	2			O	
1- 6	11B122300	Shoe cover	1	O	O	O	
1- 7	111M170801S	Screw	2				
1- 8	111M170401S	Screw	1				
1- 9	41B7325460	Accessory shoe	1			O	
1-10	17B122730	Pin	1	O	O	O	
1-11	115A1438020	Contact seat assembly	1			O	
1-12	23B1440300	Ring	1			O	
1-13	53B614070	Screw	1			O	
1-14	58B1444110	Shutter speed dial	1				
1-17	29B1441100	Dial base	1			O	
1-18	50B122540	Spring	1		O	O	
1-27	53B122190	Screw	1		O		
1-28	6B14411B0	Exposure counter window	1			O	
1-29	85A1437140	Connector assembly	1			O	
1-30	16B122170	Shutter release button	1		O		
1-32	110M170301C	Screw	2				
1-33	16A1443070	Film rewind knob assembly	1				
1-34	53B1440230	Screw	1			O	
1-35	18A1253630	Film rewind crank assembly	1	O	O	O	
1-38	17B96810	Pin	1	O	O	O	
1-39	16B1444070	Knob	1				
1-40	50B122040	Leaf spring	1		O		
1-41	115A1438010	Contact seat assembly (I)	1			O	
1-42	53B93480	Screw	1	O	O	O	
1-43	115B122760	Insulation plate	2	O	O	O	
1-44	112B122750	Contact piece	1	O	O	O	
1-45	112B122740	Contact piece	1	O	O	O	
1-70	11B120730	Bottom cover	1	O	O	O	
1-71	16B103690	Rewind button	1	O	O	O	
1-72	111M170301C	Screw	2				
1-73	59B1440760	Leather	1				
1-74	59B1444060	Leather	1				
1-75	23B380300	Clip	2			O	
1-76	302A1439700	Back cover assembly	1			O	
1-77	59B1442710	Leather	1			O	
1-79	37B1590	Roller	1	O	O	O	

Fig. 1 — 1



REF. NO.	PART NO.	PART NAME	Q'TY	COMMONLY USED WITH			REMARKS
				ST701	ST801	ST605	
1-84	59B96250	Moquette	1	O	O	O	
1-87	44A102930	Pressure plate assembly	1	O	O	O	
1-91	59B96210	Moquette	1	O	O	O	
1-93	19B96080	Hinge	1	O	O	O	
1-96	53A370570	Screw assembly	1	O	O	O	
1-97	50B120800	Leaf spring	1	O	O	O	
1-98	47A370560	Film advance lever assembly	1	O	O	O	
1-99	16B380560	Knob	1	O	O	O	
1-100	53B120880	Screw	1	O	O	O	
1-103	55B120760	Washer	1	O	O	O	
1-104	85B120750	Plate	1	O	O	O	
1-105	55B1440080	Plate	1			O	
1-106	42B1440070	Collar	1			O	
1-107	85B1440060	Screw	1			O	
1-108	110M200401S	Screw	4				
1-109	111M170201S	Screw	3				
1-119	58A1438110	Film speed dial	1			O	
1-120	16A1438080	Shutter speed dial assmbly	1			O	
1-122	50B122180	Spring	2				
1-123	110M140151S	Screw	2				
1-133	57A1437290	Cap assembly	1			O	

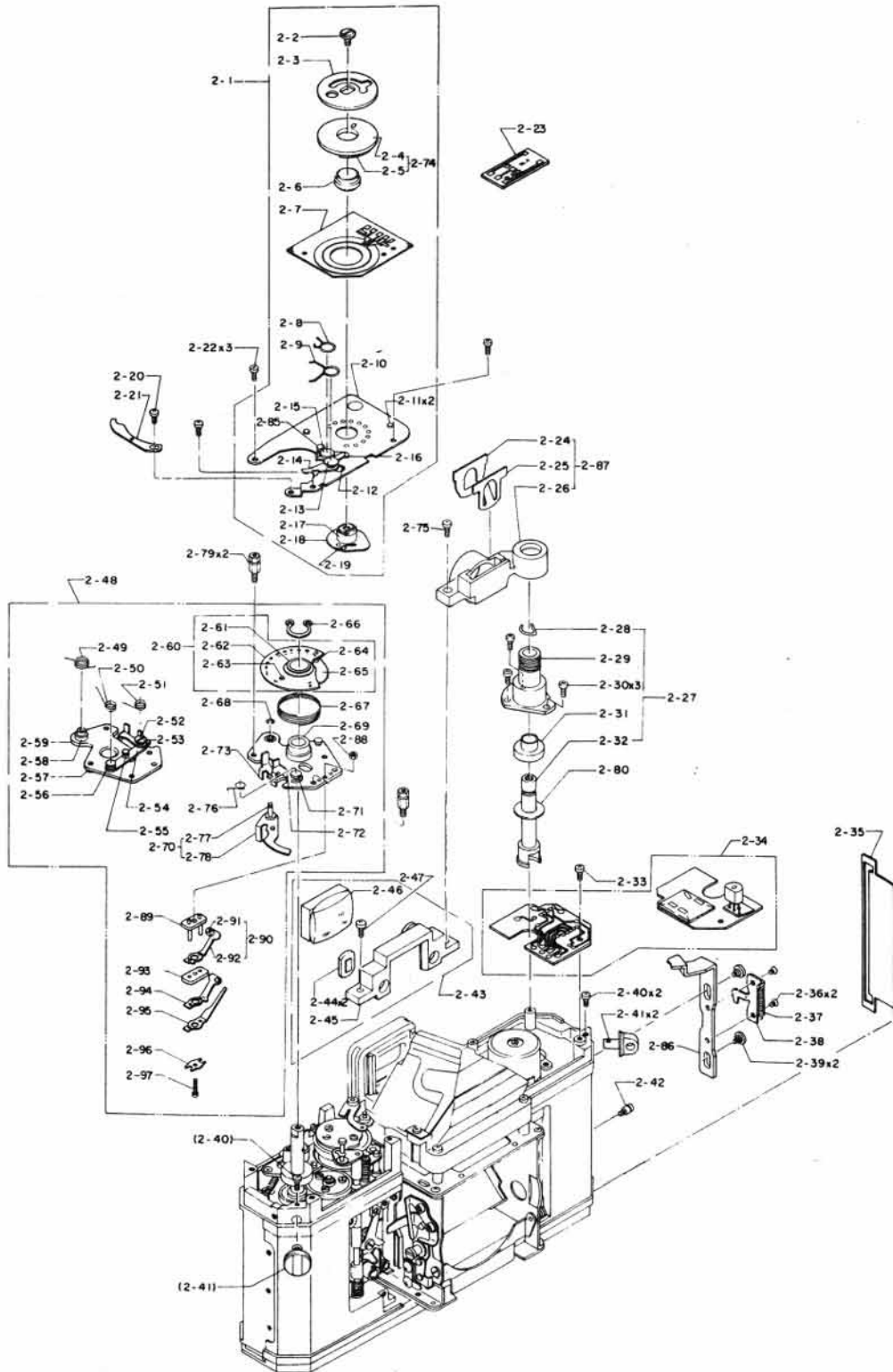
Fig. 1—2



REF. NO.	PART NO.	PART NAME	Q'TY	COMMONLY USED WITH			REMARKS
				ST701	ST801	ST605	
1-46	304A1443350	Lens mount assembly	1				
1-50	23B123020	Ring	1		O		
1-51	23B123030	Mount ring	1		O		
1-52	53B384510	Screw	1		O		
1-56	16A123980	Stop-down aperture button assembly	1				
1-57	59B1440950	Leather	1				
1-60	50B123160	Spring	1		O		
1-62	16A123940	Button	1		O		
1-63	16B95220	Button	1		O		
1-64	50B95230	Spring	1		O		
1-65	55B95280	Washer S1	0 ~	O	O	O	
	167M23005	Washer S2	0 ~	O	O	O	
	55B95390	Washer S3	0 ~	O	O	O	
1-66	32B95300	Shaft	1		O		
1-67	33B95370	Coupling	1	O	O	O	
1-68	191M15	E-clip	1		O		
1-69	191M08	E-clip	1		O		
1-119	110M170281C	Screw	4		O		
1-123	111M170301S	Screw	4		O		
1-124	17B123190	Pin	1		O		
1-125	50B123200	Spring	1		O		
1-127	27B123380	Moquette	1		O		
1-128	50B123050	Plate	2		O		
1-129	85B123060	Holder	2		O		
1-130	53B123320	Screw	4		O		
1-131	42B123330	Bushing S1	0 ~ 4		O		
	42B123400	Bushing S2	0 ~ 4		O		
	42B123410	Bushing S3	0 ~ 4		O		
1-132	53B123180	Screw	1		O		
1-134	23A123990	Aperture transmission ring assembly	1		O		

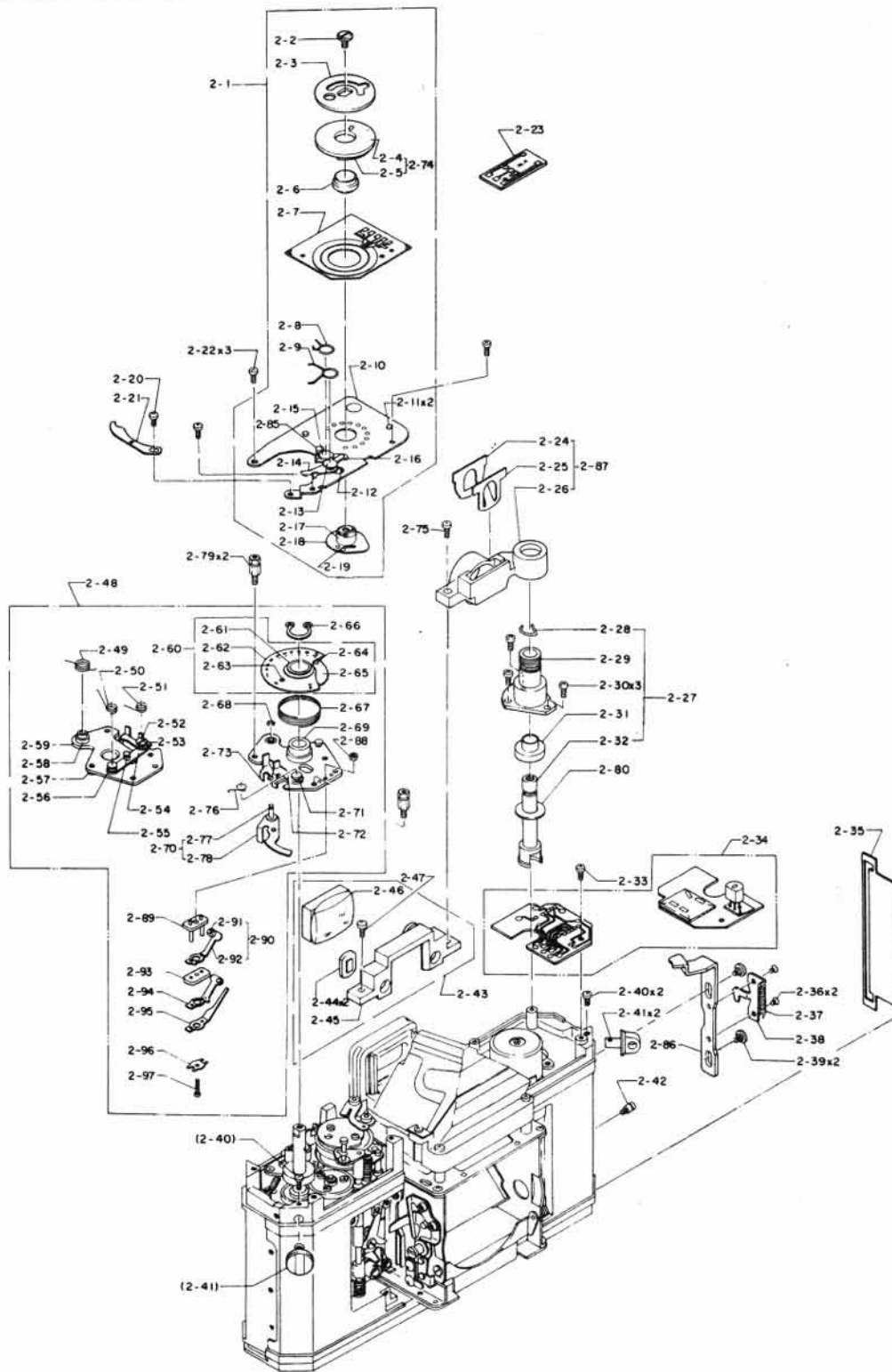


Fig. 2



REF. NO.	PART NO.	PART NAME	Q'TY	COMMONLY USED WITH			REMARKS
				ST701	ST801	ST605	
2- 1	305A143300	Shutter resistor assembly	1				
2- 2	53B1442010	Screw	1			O	
2- 3	85B1442000	Connector plate	1			O	
2- 6	32B1441970	Shaft	1				
2- 7	110B1441960	Printed circuit board	1				
2- 8	50B1441900	Spring	1			O	
2- 9	50B1441920	Spring	1			O	
2-18	85A1438820	Click plate assembly	1			O	
2-20	110M140201S	Screw	1				
2-21	65B1440120	Index plate	1			O	
2-22	110M170301S	Screw	3				
2-23	110A1443550	Printed circuit board	1				
2-24	115B1440270	Insulation plate	1			O	
2-25	50B1440260	Contact spring	1			O	
2-26	12B1440250	Battery case	1			O	
2-27	311A1437720	Rewind shaft assembly	1			O	
2-28	50B1440750	Click spring	1			O	
2-29	32B1440720	Sleeve	1			O	
2-30	110M170301S	Screw	3				
2-31	27B1440740	Ring	1			O	
2-32	32B1440730	Rewind shaft	1			O	
2-33	110M170401S	Screw	1				
2-34	110A1443500	Amplifier assembly	1				
2-35	19B96150	Cover	1	O	O	O	
2-36	111M170201S	Screw	2				
2-37	50B96130	Spring	1	O	O	O	
2-38	19B380800	Plate	1	O	O	O	
2-39	19B96120	Guide	2	O	O	O	
2-40	110M170401S	Screw	2	O	O	O	
2-41	41B93840	Neck strap ring	2	O	O	O	
2-42	53B96140	Spring hook	1	O	O	O	
2-43	316A1437160	Photocell assembly	1			O	
2-44	106B100530	Photocell	2			O	
2-45	12B1440160	Case	1			O	
2-46	1A1461100	Eyepiece lens	1			O	
2-47	53B1440400	Screw	1			O	
2-48	322A1443610	Counter assembly	1				
2-49	50B97630	Spring	1	O	O	O	
2-50	50B97600	Spring	1	O	O	O	
2-51	50B97590	Spring	1	O	O	O	
2-60	32A127480	Counter dial assembly	1	O	O	O	

Fig. 2

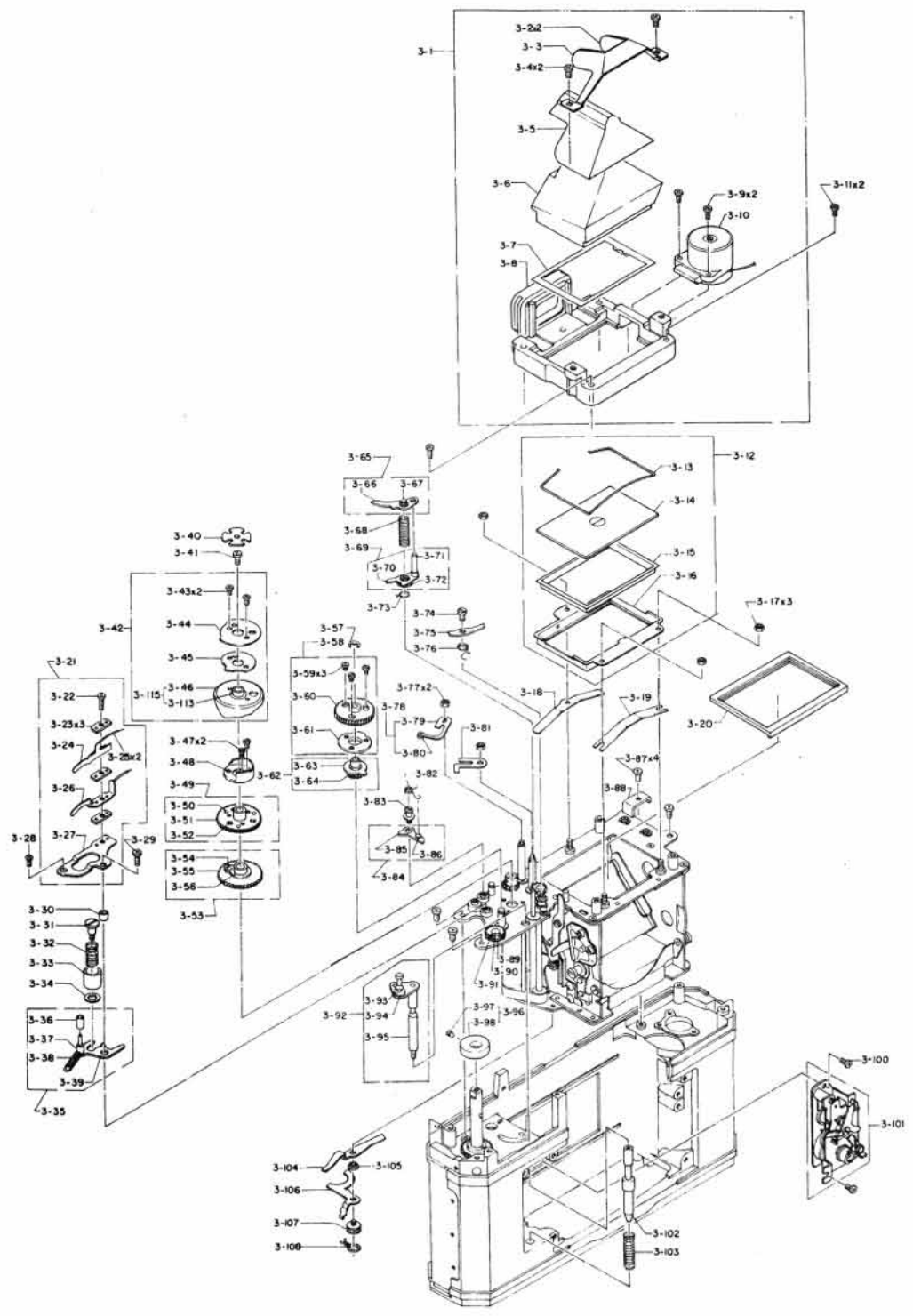


REF. NO.	PART NO.	PART NAME	Q'TY	COMMONLY USED WITH			REMARKS
				ST701	ST801	ST605	
2-66	25B97700	Clip	1	O	O	O	
2-67	50B97640	Spring	1	O	O	O	
2-68	191M08	E-clip	1	O	O	O	
2-70	47A103010	Zero reset lever assembly	1	O	O	O	
2-74	82A1438980	Contact plate assembly	1			O	
2-75	110M170953S	Screw	1			O	
2-76	50B97530	Spring	1	O	O	O	
2-79	32B97710	Column	2	O	O	O	
2-80	27B1440760	Plate	1			O	
2-86	19B1440770	Base plate	1			O	
2-87	12A1437250	Battery case assembly	1			O	
2-88	54B99530	Nut	1		O		
2-89	115B127030	Insulation plate	1		O		
2-90	322A127500	Switch contact assembly	1		O		
2-91	17B123240	Pin	1		O		
2-92	109A127460	Switch contact assembly	1		O		
2-93	115B127050	Insulation plate	1		O		
2-94	109A127470	Switch contact assembly	1		O		
2-95	50B127070	Leaf spring	1		O		
2-96	55B127080	Washer	1		O		
2-97	110M140501C	Screw	1		O		



REF. NO.	PART NO.	PART NAME	Q'TY	COMMONLY USED WITH			REMARKS
				ST701	ST801	ST605	
3- 1	12A1443620	Penta prism assembly	1				
3- 2	51B1442480	Moquette	2			O	
3- 3	56B1442470	Plate	1			O	
3- 4	113M170403S	Screw	2			O	
3- 5	11B1442490	Cover	1			O	
3- 6	2B1589240	Prism	1				
3- 7	20B1442460	Frame	1			O	
3- 8	12B1442450	Case	1			O	
3- 9	113M170403S	Screw	2			O	
3-10	107A1439400	Meter assembly	1			O	
3-11	110M170301S	Screw	2				
3-12	12A1437170	Focusing screen assembly	1			O	
3-13	50B1440180	Holder	1			O	
3-14	5B1303680	Focusing glass	1	O		O	
3-15	11B101720	Cover	1	O	O	O	
3-16	12B1440170	Case	1			O	
3-17	54B1440210	Nut	3			O	
3-18	50B1440200	Leaf spring	1			O	
3-19	50B1440190	Leaf spring	1			O	
3-20	27B98260	Frame	1	O	O	O	
3-21	46A103320	Synchro contact assembly	1	O	O	O	
3-22	110M140451S	Screw	1	O	O	O	
3-23	115B99680	Insulation plate	3	O	O	O	
3-24	109B99700	Contact plate	1	O	O	O	
3-26	109B99690	Contact plate	1	O	O	O	
3-27	46B99670	Base plate	1	O	O	O	
3-28	111M170301S	Screw	1	O	O	O	
3-29	110M170501S	Screw	1	O	O	O	
3-30	42B99710	Collar	1	O	O	O	
3-31	53B99180	Screw	1	O	O	O	
3-32	50B99170	Spring	1	O	O	O	
3-33	42B99150	Insulation collar	1	O	O	O	
3-34	55B91160	Washer	1	O	O	O	
3-35	87A103180	Brake assembly	1	O	O	O	
3-36	37B99650	Insulation roller	1	O	O	O	
3-38	50B99660	Spring	1				
3-40	33B1440110	Coupling	1			O	
3-41	53B93480	Screw	1	O	O	O	
3-42	35A126940	Shutter cam assembly	1				
3-43	53B126590	Screw	2		O	O	

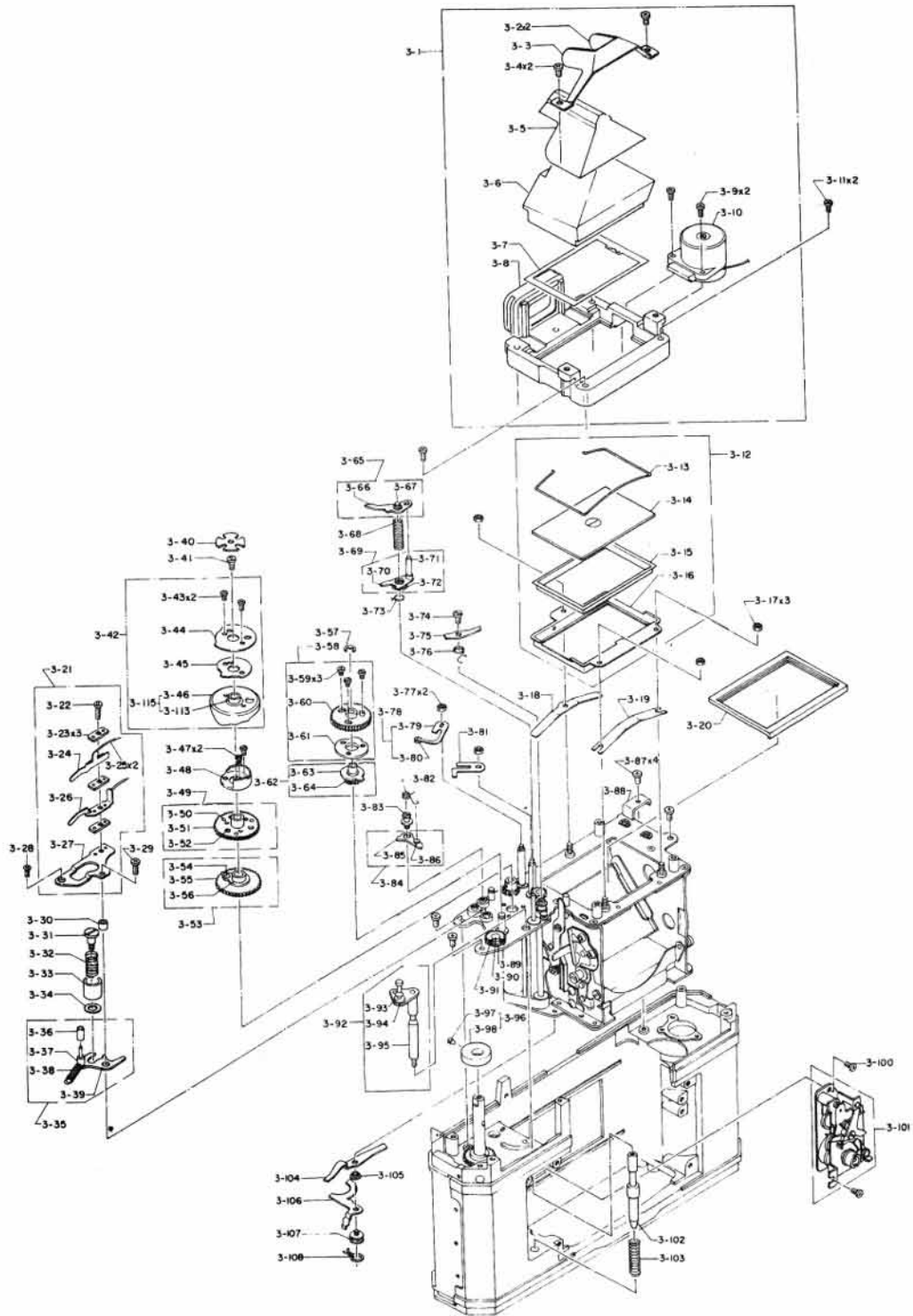
Fig. 3



REF. NO.	PART NO.	PART NAME	Q'TY	COMMONLY USED WITH			REMARKS
				ST701	ST801	ST605	
3-44	35B98910	Cam	1	○			
3-45	35B126520	Cam plate	1		○		
3-47	53B98870	Screw	2	○	○	○	
3-48	35B1444210	Cam	1				
3-49	34A103490	1st blind gear assembly (S1)	0~1	○	○	○	
	34A103500	1st blind gear assembly (S2)	0~1	○	○	○	
	34A103510	1st blind gear assembly (S3)	0~1	○	○	○	
3-53	34A103460	2nd blind gear assembly (S1)	0~1	○	○	○	
	34A103470	2nd blind gear assembly (S2)	0~1	○	○	○	
	34A103480	2nd blind gear assembly (S3)	0~1	○	○	○	
3-57	191M15	E-clip	1	○		○	
3-58	34A103110	Clutch plate assembly	1	○		○	
3-59	100M170163S	Screw	3	○		○	
3-60	34B98790	Clutch gear	1	○		○	
3-61	33B98780	Clutch plate	1	○		○	
3-62	34A103100	Clutch gear assembly	1	○		○	
3-65	47A103160	Kick lever assembly	1	○	○	○	
3-68	50B98980	Spring	1	○	○	○	
3-69	47A103150	Stopper lever assembly	1	○	○	○	
3-70	47B98950	Lever	1	○	○	○	
3-71	17B98960	Pin	1	○	○	○	
3-72	32B98940	Sleeve	1	○	○	○	
3-73	50B98970	Spring	1	○	○	○	
3-74	53B99050	Screw	1	○	○	○	
3-75	45B99030	Claw	1	○	○	○	
3-76	50B99040	Spring	1	○	○	○	
3-77	54B99530	Nut	2	○	○	○	
3-78	47A103300	Lever assembly	1			○	
3-81	47B99520	Cam lever	1	○	○	○	
3-82	50B99100	Spring	1	○	○	○	
3-83	53B99090	Screw	1	○	○	○	
3-84	47A103170	Brake lever assembly	1	○	○	○	
3-87	110M200301S	Screw	4	○	○	○	
3-88	85B99720	Bracket	1	○	○	○	

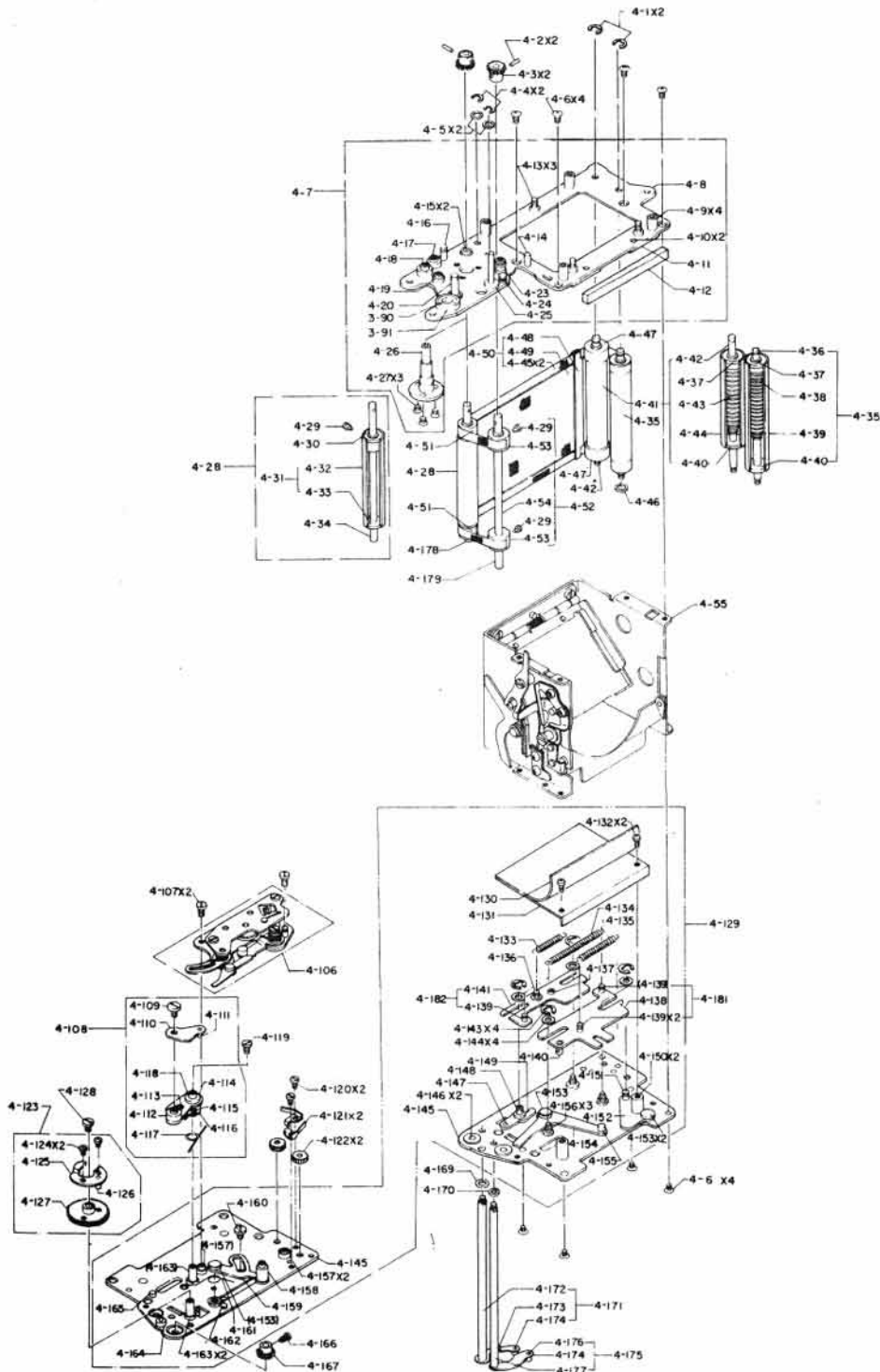


Fig. 3



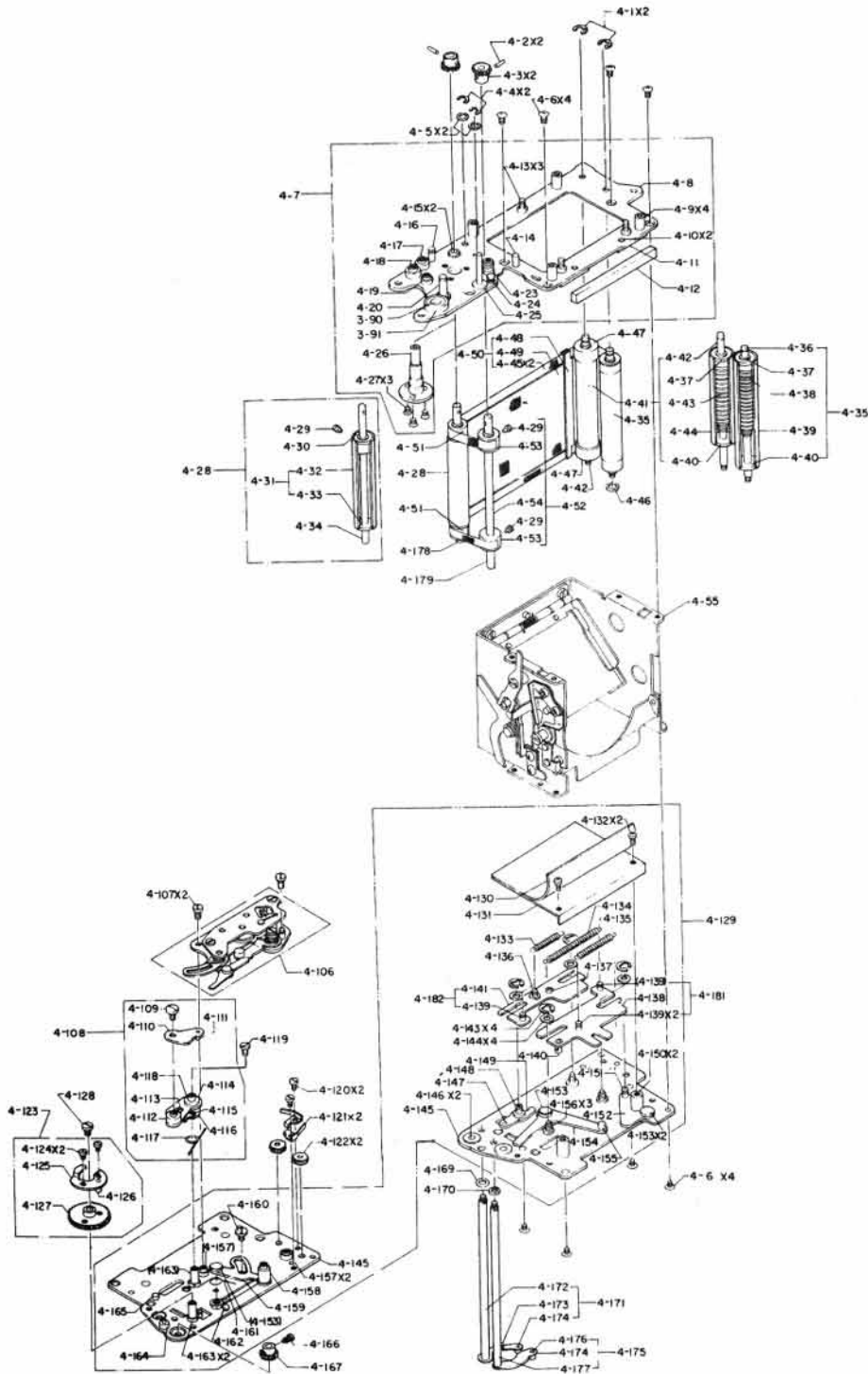
REF. NO.	PART NO.	PART NAME	Q'TY	COMMONLY USED WITH			REMARKS
				ST701	ST801	ST605	
3-92	85A1437090	Shutter release shaft assembly	1			O	
3-96	35A102760	Eccentric cam assembly	1	O		O	
3-97	53B93740	Screw	1	O	O	O	
3-98	35B93730	Eccentric cam	1	O		O	
3-100	110M200301S	Screw	2				
3-101	307A103450	Self-timer assembly	1	O	O	O	
3-102	32B99580	Release shaft	1	O	O	O	
3-103	50B99620	Spring	1	O	O	O	
3-104	47B94810	Lever	1	O		O	
3-105	32B94820	Sleeve	1	O		O	
3-106	47B94850	Brake lever	1	O		O	
3-107	53B94830	Screw	1	O		O	
3-108	50B94840	Spring	1	O		O	
3-115	35A126930	Shutter cam assembly	1				

Fig. 4—1



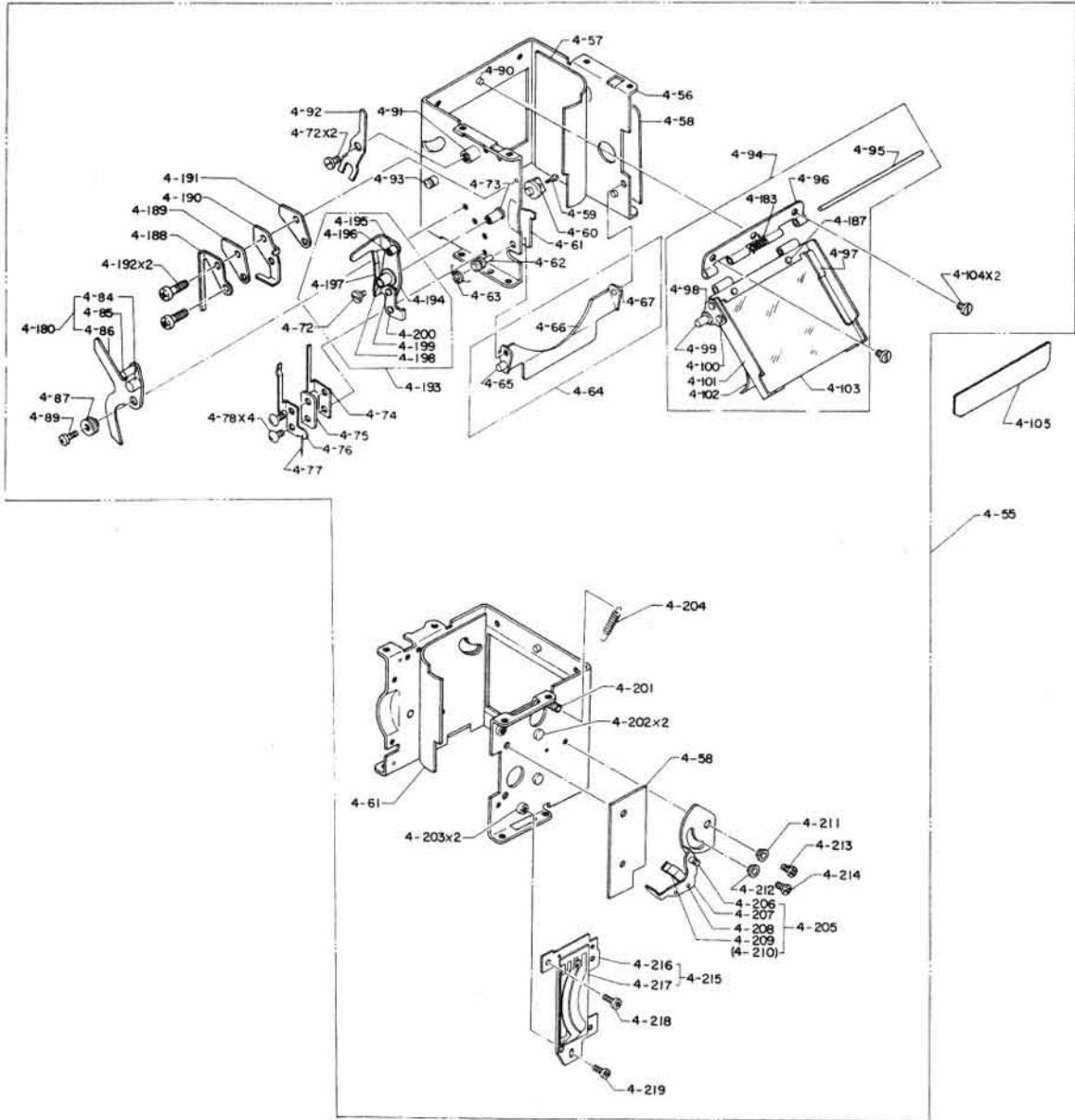
REF. NO.	PART NO.	PART NAME	Q'TY	COMMONLY USED WITH			REMARKS
				ST701	ST801	ST605	
4- 1	191M15	E-clip	2	○	○	○	
4- 2	17B99380	Pin	2	○	○	○	
4- 3	34B99370	Gear	2	○	○	○	
4- 4	191M15	E-clip	2	○	○	○	
4- 5	55B99510	Washer	1 ~	○	○	○	
4- 6	111M170221S	Screw	4				
4- 7	46A1439550	Shutter base plate assembly	1			○	
4-12	51B99740	Moquette	1	○	○	○	
4-26	32B126540	Shaft	1			○	
4-27	111M170161S	Screw	3				
4-46	55B99240	Washer	1	○	○	○	
4-47	37B99290	Roller	2	○	○	○	
4-51	37B99350	Roller	1	○	○	○	
4-55	308A1443450	Mirror box assembly	1				
4-106	307A102940	Governor assembly	1	○	○	○	
4-107	53B93480	Screw	2	○	○	○	
4-108	32A102830	Claw lever assembly	1	○	○	○	
4-109	53B94790	Screw	1	○	○	○	
4-117	50B94710	Spring	1	○	○	○	
4-119	53B93480	Screw	1	○	○	○	
4-120	100M170121B	Screw	2				
4-121	45B94800	Claw	2	○		○	
4-122	34B99250	Ratchet wheel	2	○		○	
4-123	34A102810	Gear assembly	1	○	○	○	
4-124	110M140151S	Screw	2	○	○	○	
4-127	34B94680	Gear	1	○	○	○	
4-128	53B93480	Screw	1	○	○	○	
4-129	306A102780	Quick return mechanism assembly	1	○	○	○	
4-130	27B94860	Light shielding paper	1	○	○	○	
4-131	11B94660	Cover	1	○	○	○	
4-132	110M140301S	Screw	2	○	○	○	
4-133	50B94630	Spring	1	○	○	○	
4-134	50B94640	Spring	1	○	○	○	
4-135	50B94650	Spring	1	○	○	○	
4-143	191M15	E-clip	4	○	○	○	
4-144	55B94620	Washer	4	○	○	○	
4-160	53B94550	Screw	1	○	○	○	
4-161	50B94670	Spring	1	○	○	○	
—	305A1443200	Focal plane shutter assembly	1				

Fig. 4-1



REF. NO.	PART NO.	PART NAME	Q'TY	COMMONLY USED WITH			REMARKS
				ST701	ST801	ST605	
4-166	53B99420	Screw	1	0	0	0	
4-167	34B99410	Gear	1	0	0	0	
4-169	55B99510	Washer	1	0	0	0	
4-170	42B99500	Collar	1	0	0	0	
4-171	47A103280	Lower cam lever assembly	1	0	0	0	
4-175	47A103290	Lower lever assembly	1	0	0	0	
4-178	32A103190	2nd blind assembly	1			0	
4-179	32A103210	1st blind assembly	1			0	
4-181	29A102790	Plate assembly	1	0	0	0	
4-182	29A102800	Plate assembly	1	0	0	0	

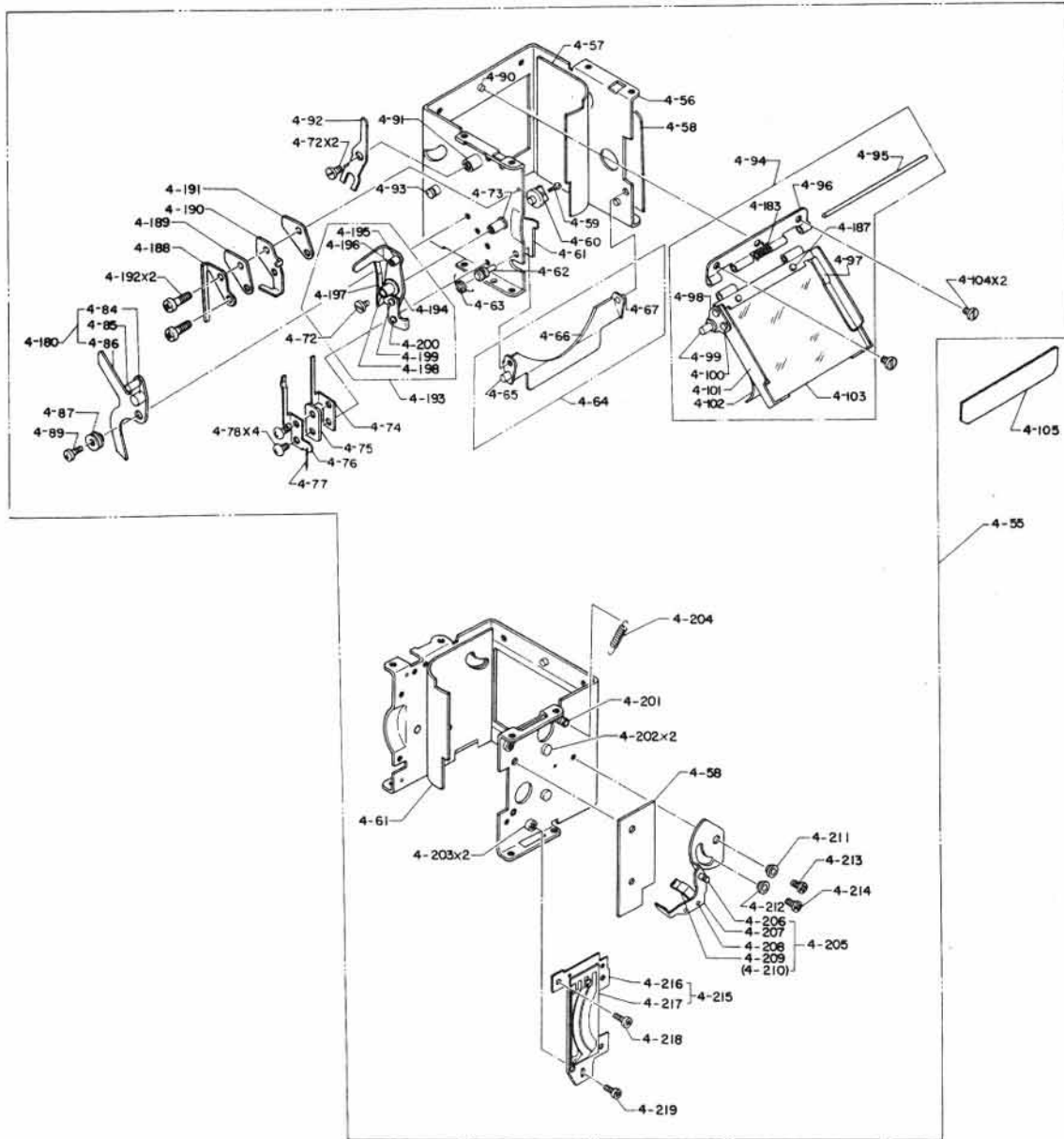
Fig. 4—2



REF. NO.	PART NO.	PART NAME	Q'TY	COMMONLY USED WITH			REMARKS
				ST701	ST801	ST605	
4-55	308A1443450	Mirror box assembly	1				
4-57	27B98360	Light shielding paper	1	O	O	O	
4-58	27B124410	Light shielding paper	1	O	O	O	
4-59	111M140403S	Screw	1				
4-61	27B98370	Light shielding paper	1	O	O	O	
4-62	17B124320	Pin	1	O	O	O	
4-63	50B98170	Spring	1	O	O	O	
4-64	29A124970	Aperture setting plate assembly	1	O	O	O	
4-72	53B93480	Screw	1	O	O	O	
4-73	32B97920	Shaft	1	O	O	O	
4-74	112B98220	Synchro-contact	1	O	O	O	
4-75	115B98230	Insulator plate	1	O	O	O	
4-76	112B98240	Synchro-contact	1	O	O	O	
4-77	110B1253890	Lead wire	1	O	O		
4-78	53K1580	Screw	2	O	O	O	
4-87	32B98430	Sleeve	1	O	O	O	
4-89	110M1704015	Screw	1				
4-90	17B98390	Pin	1	O	O	O	
4-91	32B97930	Shaft	1	O	O	O	
4-92	47B97950	Lever	1	O	O	O	
4-94	29A1255120	Mirror assembly	1			O	
4-95	19B98110	Hinge shaft	1	O	O	O	
4-96	19B98060	Hinge	1	O	O	O	
4-102	27B98380	Light shielding paper	1	O	O	O	
4-103	3B1303670	Mirror	1			O	
4-183	50B383080	Spring	1	O	O	O	
4-104	53B98120	Screw	2	O	O	O	
4-105	27B98250	Blind	1	O	O	O	
4-180	47A103570	Mirror shifter lever assembly	1	O	O	O	
4-188	109B124270	Contact piece	1		O		
4-189	115B124290	Insulation plate	1		O		
4-190	109B124280	Contact piece	1		O		
4-191	115B124290	Insulation plate	1		O		
4-192	53K19860	Screw	1		O		
4-193	47A124980	Stop-down interlock lever assembly	1		O		
4-204	50B124090	Spring	1		O		
4-205	47A1443460	Rotary plate assembly	1				

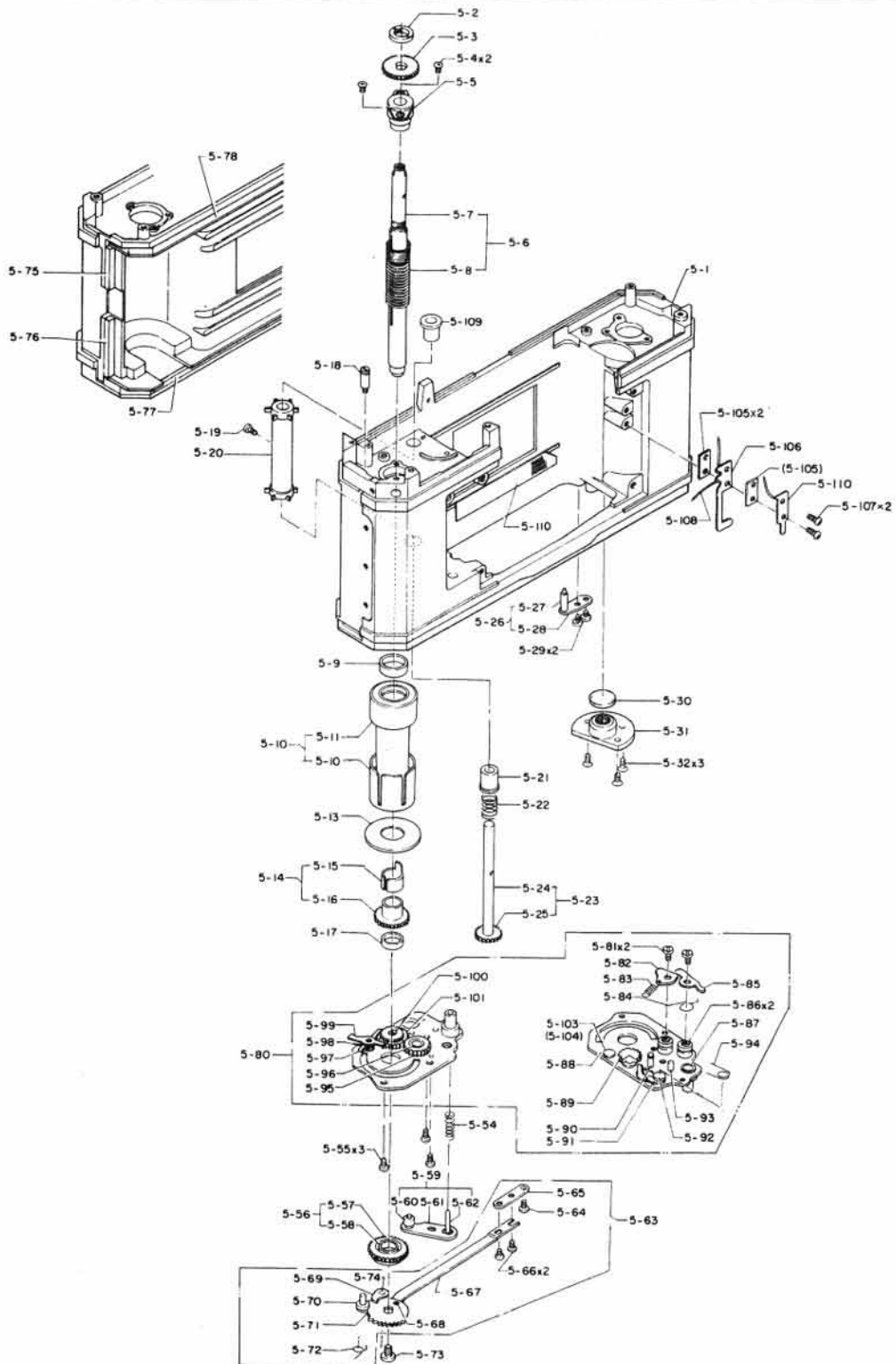


Fig. 4-2



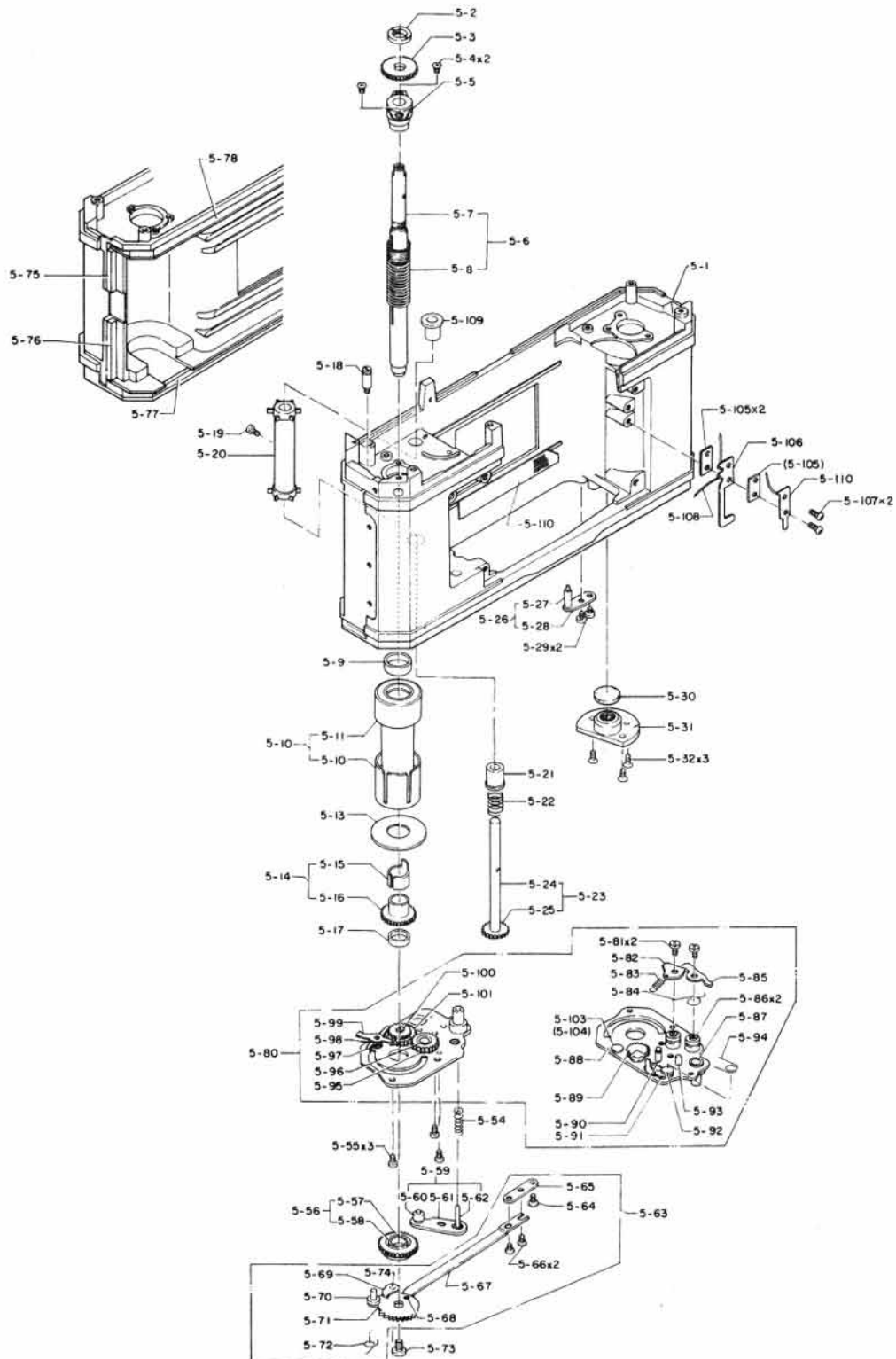
REF. NO.	PART NO.	PART NAME	Q'TY	COMMONLY USED WITH			REMARKS
				ST701	ST801	ST605	
4-211	42B124030	Bushing	1		O		
4-212	42B124050	Bushing	1		O		
4-213	110M170251S	Screw	1				
4-214	110M140251S	Screw	1				
4-215	46A1443480	Aperture resistor assembly	1				
4-218	110B14021S	Screw	1		O		
4-219	53B124440	Screw	1		O		

Fig. 5



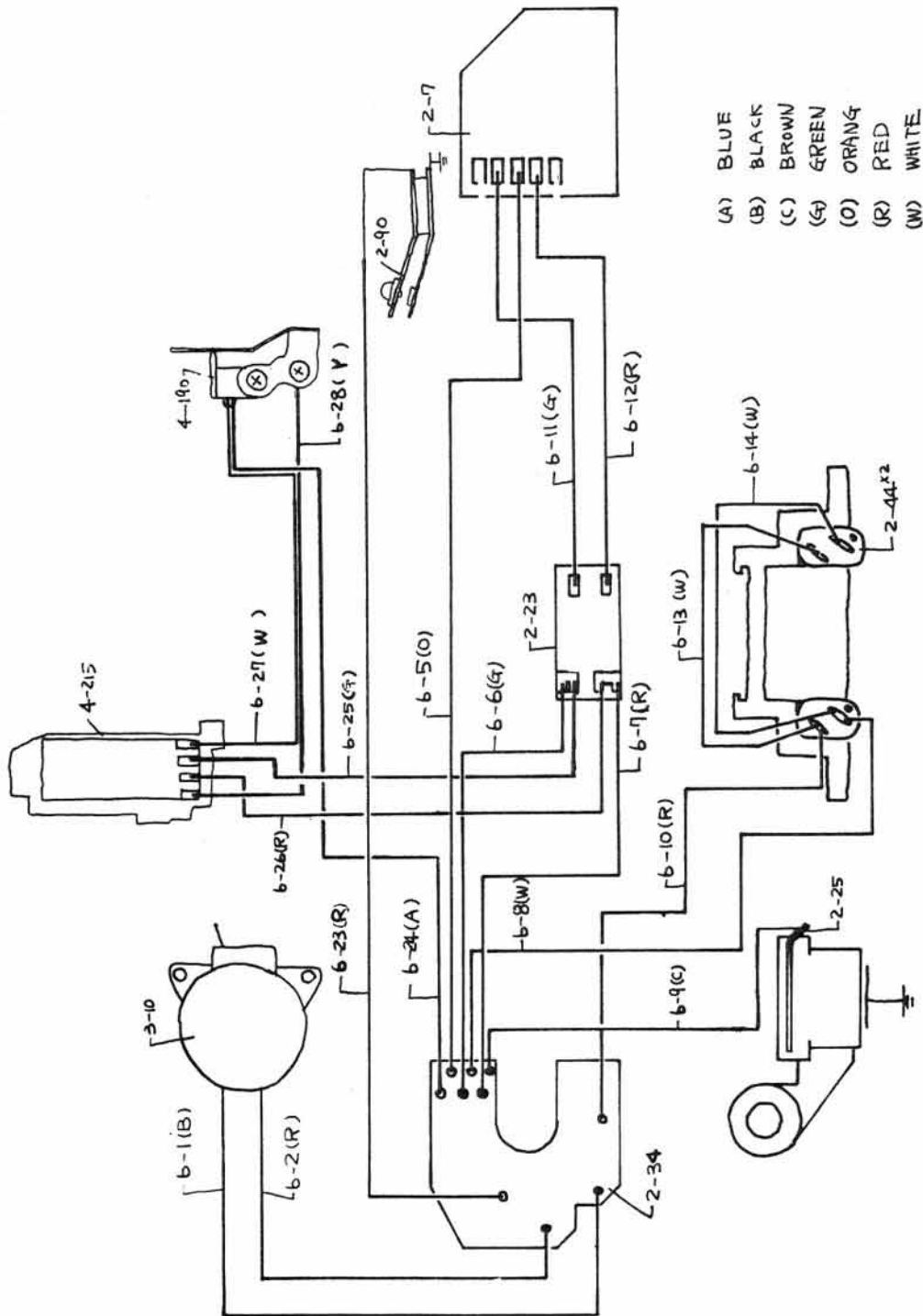
REF. NO.	PART NO.	PART NAME	Q'TY	COMMONLY USED WITH			REMARKS
				ST701	ST801	ST605	
5- 1	10B1440700	Body proper	1			O	
5- 2	53B93320	Ring	1	O	O	O	
5- 3	34B93310	Gear	1	O		O	
5- 4	111M170301S	Screw	1				
5- 5	31B93300	Holder	1	O	O	O	
5- 6	32A143770	Spool shaft assembly	1			O	
5- 7	32B1440710	Spool shaft	1			O	
5- 8	50B93290	Spring	1	O	O	O	
5- 9	42B93330	Bushing	1			O	
5-10	37A102700	Spool assembly	1	O	O	O	
5-13	55B93350	Washer	1	O	O	O	
5-14	34A102710	Spool gear assembly	1	O		O	
5-15	50B1390	Friction plate	1	O		O	
5-16	34B93360	Spool gear	1	O		O	
5-17	42B93380	Collar	1	O		O	
5-18	53B93790	Screw	1	O	O	O	
5-19	53B93270	Screw	1	O	O	O	
5-20	34B93220	Sprocket	1	O	O	O	
5-21	32B94320	Sleeve	1			O	
5-22	50B93250	Spring	1	O	O	O	
5-23	32A102680	Sprocket shaft assembly	1	O		O	
5-26	85A102770	Positioning plate assembly	1	O	O	O	
5-29	110M200301S	Screw	2				
5-30	27B93890	Moquette	1	O	O	O	
5-31	53B93820	Tripod socket	1	O	O	O	
5-32	111M200401S	Screw	3				
5-54	50B93720	Spring	1	O	O	O	
5-55	110M200401S	Screw	3				
5-56	34A102730	Ratchet wheel assembly	1	O		O	
5-59	86A102750	Rewind button assembly	1	O	O	O	
5-63	34A102740	Ratchet plate assembly	1	O	O	O	
5-64	53B93480	Screw	1	O	O	O	
5-65	48B93650	Connecting plate	1	O		O	
5-66	110M170201C	Screw	2	O		O	
5-72	50B93680	Spring	1	O		O	
5-73	53B93670	Screw	1	O		O	
5-74	32B93630	Shaft	1	O		O	
5-75	27B93990	Moquette	1	O	O	O	
5-76	27B93980	Moquette	1	O	O	O	
5-77	27B94300	Moquette	1	O	O	O	

Fig. 5



REF. NO.	PART NO.	PART NAME	Q'TY	COMMONLY USED WITH			REMARKS
				ST701	ST801	ST605	
5-78	27B94290	Moquette	1	0	0	0	
5-80	46A102720	Base plate assembly	1	0		0	
5-81	53B93480	Screw	2	0	0	0	
5-82	47B93490	Lever	1	0	0	0	
5-83	50B93500	Spring	1	0	0	0	
5-84	50B93460	Spring	1	0	0	0	
5-85	47B93470	Lever	1	0	0	0	
5-94	50B93570	Spring	1	0	0	0	
5-95	34B93510	Idle gear	1	0		0	
5-96	32B93520	Gear shaft	1	0		0	
5-97	47B126070	Stop lever	1	0	0	0	
5-98	50B126130	Spring	2	0	0	0	
5-99	47B126060	Stop lever	1	0	0	0	
5-103	32B126090	Shaft	1	0	0	0	
5-104	32B126080	Sleeve	1	0	0	0	
5-105	115B93920	Insulation plate	1	0	0	0	
5-106	109B126030	X-contact plate	1	0	0	0	
5-107	53K19860	Screw	2	0	0	0	
5-108	110B1440600	Lead wire				0	
5-109	32B94330	Sleeve	1	0		0	
5-110	27B94310	Blind	1	0	0	0	

Fig. 6



REF. NO.	PART NO.	PART NAME	Q'TY	COMMONLY USED WITH			REMARKS
				ST701	ST801	ST605	
6- 3	110B1440470	Lead wire (yellow)	1				
6- 4	110B1440560	Lead wire (blue)	1				
6- 5	110B1440520	Lead wire (orange)	1			O	
6- 6	110B1440550	Lead wire (green)	1			O	
6- 7	110B1440570	Lead wire (red)	1			O	
6- 8	110B1440500	Lead wire (white)	1			O	
6- 9	110B1564710	Lead wire (brown)	1			O	
6-10	110B1440510	Lead wire (red)	1			O	
6-11	110B1440530	Lead wire (green)	1			O	
6-12	110B1440540	Lead wire (red)	1			O	
6-13	110B1440480	Lead wire (red)	1			O	
6-14	110B1440490	Lead wire (white)	1			O	
6-23	110B1604520	Lead wire (red)	1				
6-24	110B1604530	Lead wire (blue)	1				
6-25	110B1604570	Lead wire (green)	1				
6-26	110B1604560	Lead wire (red)	1				
6-27	110B1604550	Lead wire (white)	1				
6-28	110B1604540	Lead wire (yellow)	1				